

CATSKILL

C R A F T S M E N , I N C .

Assembly Instructions Model 1426

The Americana WorkCenter



GENERAL:

1. You have purchased model 1426.
2. Should you need assistance or need to replace a damaged or missing part simply give us a call M-F at 607-652-7321 from 7:30 am - 4:30 pm EST and we'll send you the prepaid part via UPS usually that same day! You may also email us info@catskillcraftsmen.com.
3. These units are ready-to-assemble. Catskill uses positive fastening methods such as wood screws and in some places hidden Bastion Fasteners. You will need some standard household tools: hammer and screwdriver (power screwdriver is recommended). Where possible, we have packaged some of the screws in separate labeled packages. To keep hardware separate after packets are open, we suggest you place each type of screw into separate containers. Note labels for screws and when they are to be used in assembly in the instructions.
4. Directions (left/right, front/back) are given as facing the front of an assembled upright unit.
5. A friend is recommended to assist with assembly as this will ease the process. Some of the parts are large and awkward to hold in place, and extra pair of hands are a huge help.

Parts List

Model 1426



(2) Right Front / Left Back Leg
30" x 2.5" x 2.5"
Part #: Leg-1426RFLB



(2) Left Front / Right Back Leg
30" x 2.5" x 2.5"
Part #: Leg-1426LFRB



(1) Top Back Brace
41" x 5-1/2" x 3/4"
Part #: TBB1426

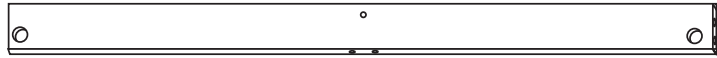

(2) Front Center/Bottom Brace
41" x 2" x 3/4"
Part #: FCBB1426

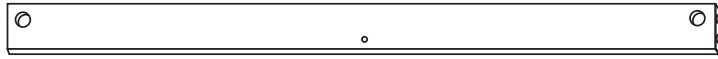

(2) Back Center/Bottom Brace
41" x 2" x 3/4"
Part #: BCBB1426



(2) Center Vertical Braces
11-9/16" x 2" x 3/4"
Part #: CVB1426



(4) Back/Side Panels
19-7/16" x 11-7/8" x 5/32"
Part #: BSP1426

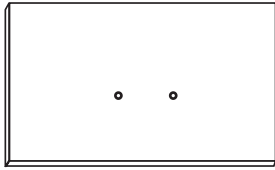

(2) Bottom Drawer Fronts
19-1/4" x 11-7/16" x 3/4"
Part #: BDF1426



(2) Bottom Drawer Backs
18-1/2" x 8" x 3/4"
Part #: BDB1426



(2) Bottom Drawer Bottom
18-5/8" x 17-5/8" x 5.2mm
Part #: BDBottom1426



(1) Center Bottom Glide Support Stick
22-1/16" x 2" x 3/4"
Part #: CBGSS1426

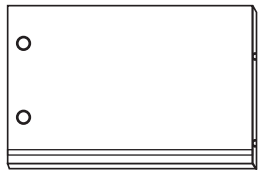

(2) Bottom Drawer Left Side
18" x 8" x 3/4"
Part #: BDLS1426



(2) Bottom Drawer Right Side
18" x 8" x 3/4"
Part #: BDRS1426

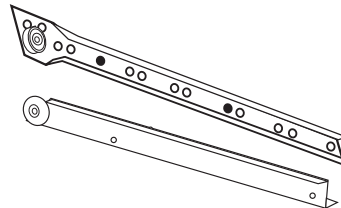

(3 sets) 20" Drawer Glide
Part #: GL-20-1426



(2) Top Side Braces
19-1/2" x 5-1/2" x 3/4"
Part #: TSB1426

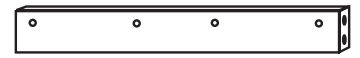

(4) Top/Bottom Side Glide Support Sticks
19-7/16" x 2" x 3/4"
Part #: TBSGSS1426



(1) Top Drawer Left Side
17" x 4-1/4" x 3/4"
Part #: TDLS1426



(1) Top Drawer Right Side
17" x 4-1/4" x 3/4"
Part #: TDRS1426



(4) 3" Locking Casters
Part #: WHEELS1426



(4) Caster Insert Sleeves
Part #: CIS1426



(4) Center/Bottom Side Braces
19-1/2" x 2" x 3/4"
Part #: CBSB1426



(1) Top Drawer Front
40-13/16" x 5-3/8" x 3/4"
Part #: TDF1426

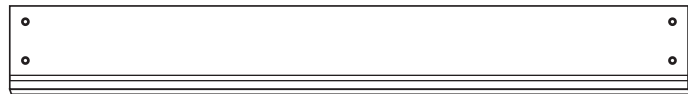

(1) Top Drawer Back
40" x 4-1/4" x 3/4"
Part #: TDB1426



(1) Top Drawer Bottom
39-1/8" x 17-5/8" x 5.2mm
Part #: TDBottom1426

CABINET HARDWARE

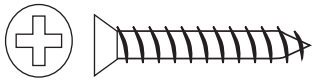

1 1/4" Phillips Flat Head #8 Screw (12)

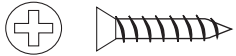

5/8" Phillips Flat Head #6 Screw (8)

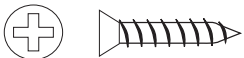

5/8" Phillips Flat Head #5 Screw (12)



3/4" Truss Head Machine Screw (8)

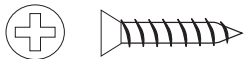

5/8" Phillips Flat Head #7 Screw (12)

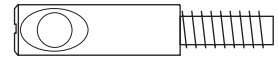

Bastion Post (34)



Bastion Set Screw (34)

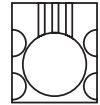

Bastion Barrel Nut (34)

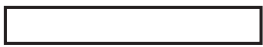

1" Long 3/16" DIA. Steel Pin (6)

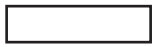

3/4" Long 3/16" DIA. Steel Pin (50)

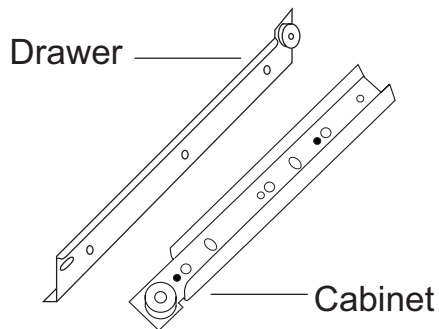

Drawer Glides (3 Sets)

The glides look almost alike however, the right glide (as you face the cart) has a rolled lip at the top of the glide that keeps the drawer glide wheel in place.

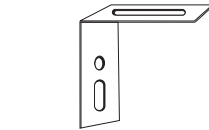

"L" Bracket (4)

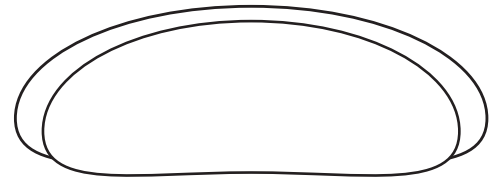

Handles (4)

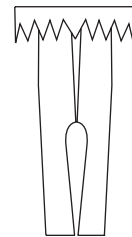

Caster Socket (4)

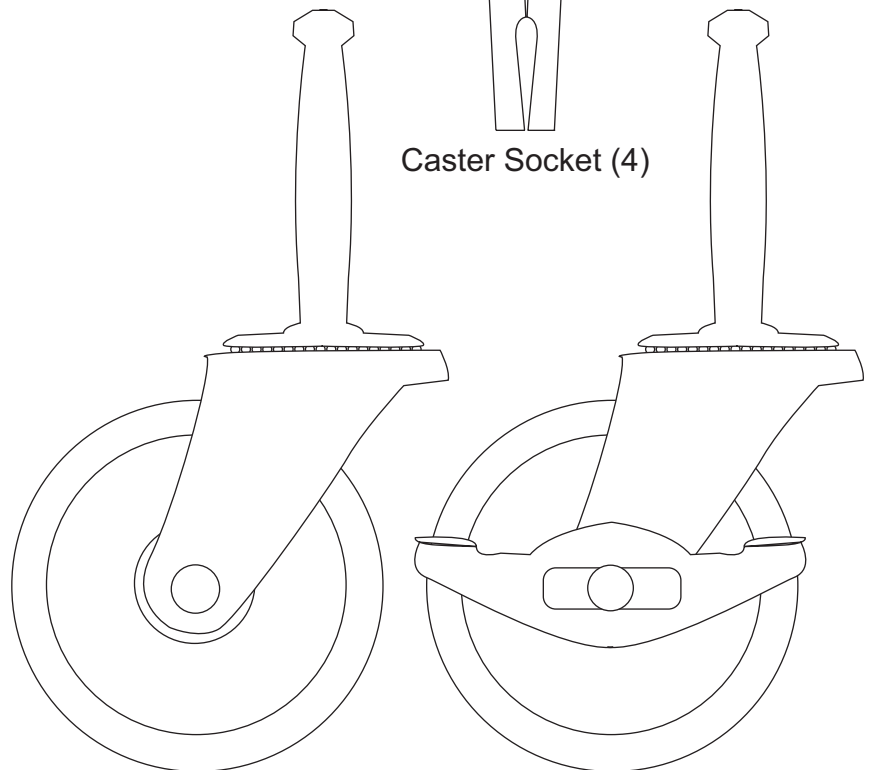

Caster (2)

Caster with Stops (2)

TIPS ON HOW THE BASTION FASTENING SYSTEM WORKS

1. The Bastion fastening system consists of a steel post (threaded on one end with a hole through the shaft on the other end); a Barrel Nut (cylindrical barrel-shaped with threaded open end & holes through the sides); and a Set Screw (Phillips slot on one end, pointed on the other)

2. To attach Posts: A) Dip threads of Post in vegetable oil. B) Align threaded end of Post with hole in wood, tap on slotted end with hard hammer until threads enter, then tighten down using a flat head screw driver or the provided allen wrench (See the Illus. Bas. 3 for alternate seating methods). **DO NOT TRY TO HAMMER THE POST ALL THE WAY IN AS IT WILL STRIP THE POST HOLE.** C) When solid shaft of Post hits wood, back out approximately 1/2 turn until the hole in the posts is properly aligned as per step by step directions. For example: the holes in the posts on the inside of the drawer front will be parallel with the long length of the drawer front when properly seated.

3. A) Place a Barrel Nut into the nut access hole, so that the threads in the nut face out. The small notches on either side of the nut opening, indicate the location of the holes through the sides of the nut. B) Insert the posts through the end of the braces (or drawer sides); through the holes in the sides of the nut. When properly aligned, you will see the hole in the post inside the barrel nut. Post hole should be slightly off-center toward the wood.

4. Insert the Set Screw into the threaded end of the nut and tighten down. The tip of the Set Screw will seek the center of the hole in the Post as it is tightened down, forcing the Nut toward the main shaft of the Post. This is what tightens the wooden parts together. Set screws should thread easily – **DON'T CROSS THREAD!** If Set Screw doesn't thread easily, check position of the hole in Post.

5. If the wooden parts are not tight against each other, the Post needs to be screwed a half turn at a time until wood joints are tight.

Illustration Bas. 1

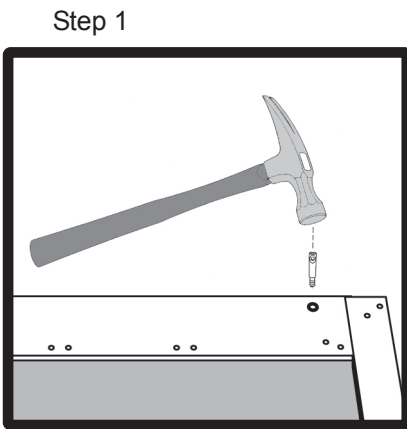
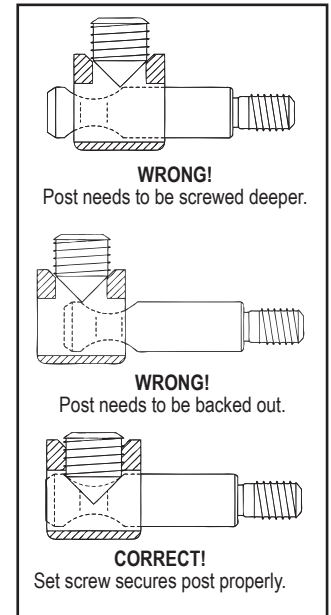
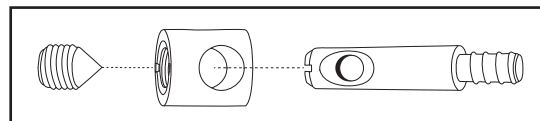
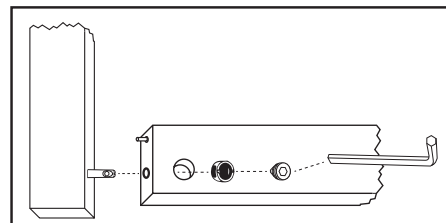

Illustration Bas. 2



Step 2



Allen Wrench Provided

Illustration Bas. 3

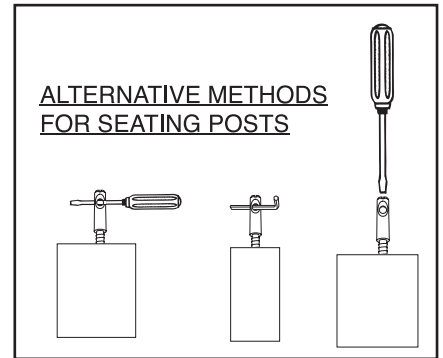

See video on our website!

If you have any questions regarding assembly or missing or damage parts, call our customer support number:

607-652-7321 or 888-732-7321.

Customer Support Hours are 8am-5pm Mon. - Fri. Eastern Time zone.

STEP 1

BACK ASSEMBLY

1. Begin assembly by laying out all of the pieces and checking against the parts list on the previous pages. Tap Caster sleeves for the caster wheels into the bottom of the legs using a standard hammer. Do not insert wheels yet. Assemble the Back Assembly by laying out the Back Right and Left Legs, Back Top Brace, Back Center Brace, Back Bottom Brace, Back Vertical Brace and the Back Bottom Panels as well as the necessary Bastions and 3/4" Steel Pins as shown in Illustration 1A.

Note: Back Center and Back Bottom Braces are slotted whereas the Front Center and Front Bottom Braces are not.

2. Tap the 3/4" Steel Pins into place on the Back Vertical Brace and attach to the Back Center and Back Bottom Braces. Slide one of the Back Bottom Panels into place, and attach the leg to the Back Center and Bottom Braces using the Bastions and 3/4" Steel Pins.

3. Next, attach the Back Top Brace to the leg using the Bastions.

4. Repeat the procedure to attach the other leg to complete Back Assembly.

5. Finally, tap the 1" steel pin into the center pilot hole on the Back Center Brace. This will be used later to support the middle shelf.

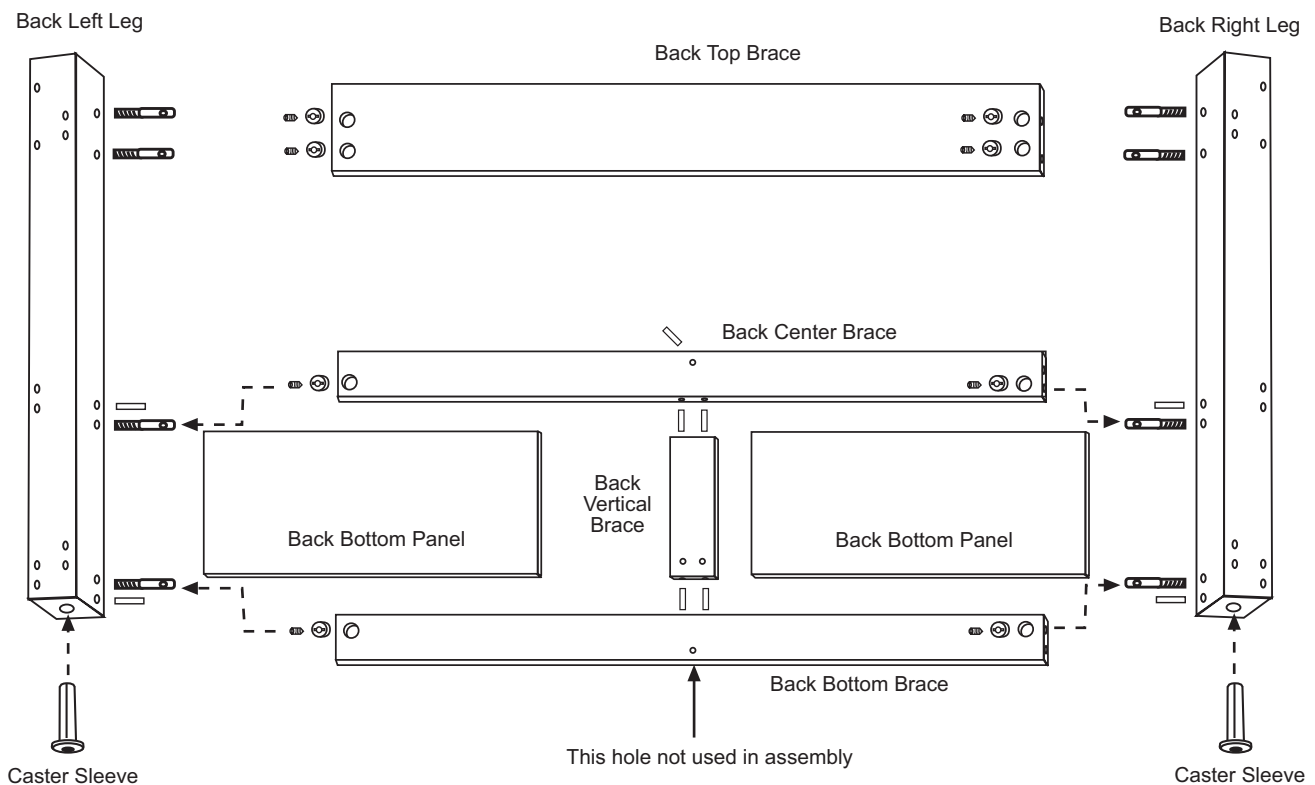

Illustration 1A

STEP 2

FRONT ASSEMBLY

Tap Caster sleeves into the bottom of the legs. Do Not insert wheels yet. Assemble the Front Assembly by laying out the Front Right and Left Legs, Front Center Brace, Front Bottom Brace, Front Vertical Brace as well as the necessary Bastions and 3/4" Steel Pins as shown in Illustration 2A. Note: Front Center and Front Bottom Braces are not slotted.

Tap the 3/4" Steel Pins into place on the Front Vertical Brace and attach to the Front Center and Front Bottom Braces. Attach the leg to the Front Center and Bottom Braces using the Bastions and Steel Pins.

Repeat the procedure to attach the other leg to complete Front Assembly.

Use Illustration 2B to properly orientate the legs and braces.

Finally, tap the 1" steel pin into the center pilot hole on the Front Center Brace. This will be used later to support the middle shelf.

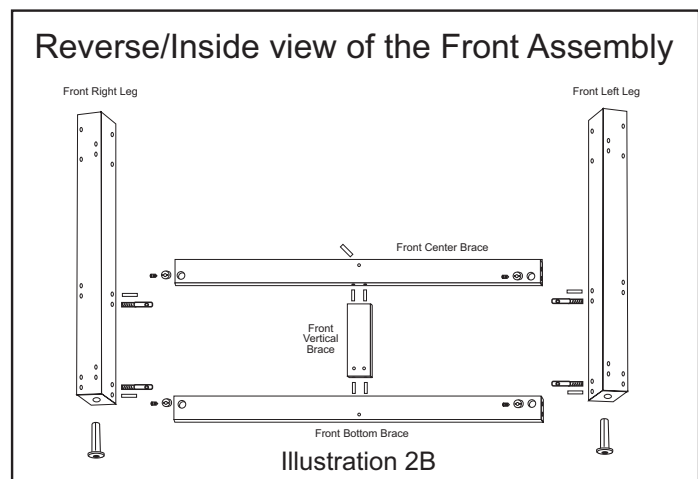
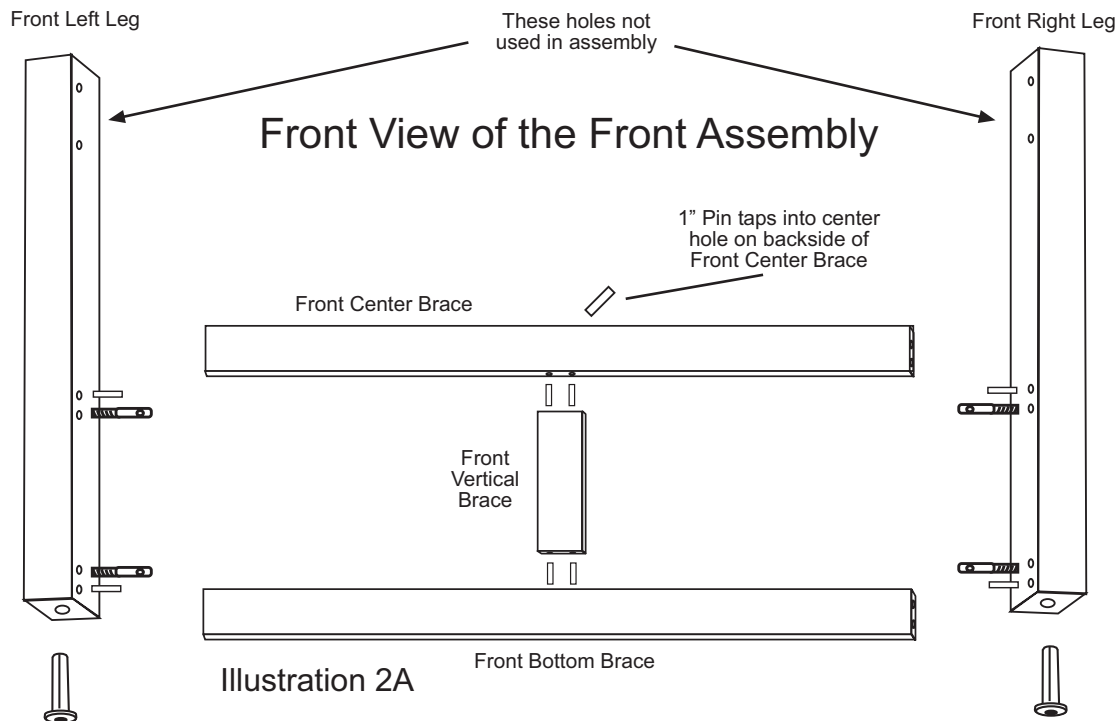

STEP 3

SIDE PANEL ASSEMBLY

Lay the Back Assembly on a smooth flat surface as in Illustration 3A. Screw the Bastion Posts into the legs and Back Vertical Brace as shown in the Bastion Fastening Instructions on Page 3. When properly seated, the screwdriver slot in the post ends will be perpendicular to the length of the legs. Tap the 3/4" Steel Pins into the legs and Back Vertical Brace. Tap 1" Steel Pins into the Center Side Braces to be used later to support the center shelf. Slide the Side Braces and Center Drawer Glide Support Stick into place, tightening the set screws.

Next, tap two 3/4" Steel Pins into each end of the four Drawer Glide Support Sticks as shown in Illustration 3A. insert one end of these sticks into the legs as illustrated while making sure that the small pilot holes for the drawer glides are toward the bottom edge and face toward the inside of the cart.

Finally slide the Bottom Side Panels into place, best side out.

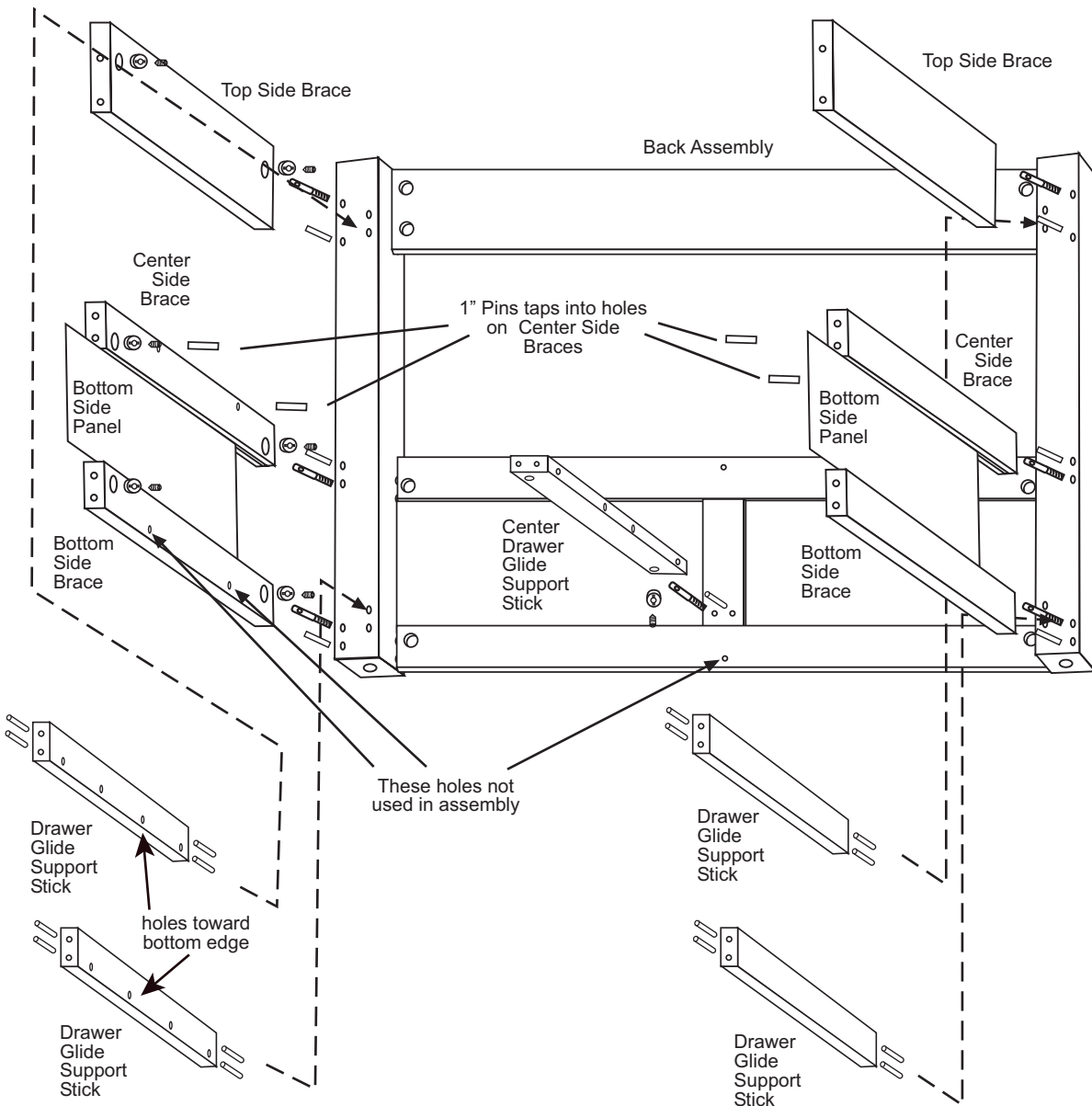

Illustration 3A

STEP 4

ATTACHING FRONT ASSEMBLY

Upright Back Assembly with Braces, etc. Attached from Step 3. Caster holes in legs should be facing down as shown in Illustration 4A. Attach Bastion Posts and tap in 3/4" Steel Pins into front legs and Front Vertical Brace. Working Right to left, slide the bastion posts and 3/4" Steel Pins into the Side Braces, waiting to tighten set screws until the Center Drawer Glide Support Stick and the Left Side Braces are all seated properly.

Drawer Glide Support Sticks should also be inserted into the Front Assembly, using the previously inserted 3/4" Steel Pins.

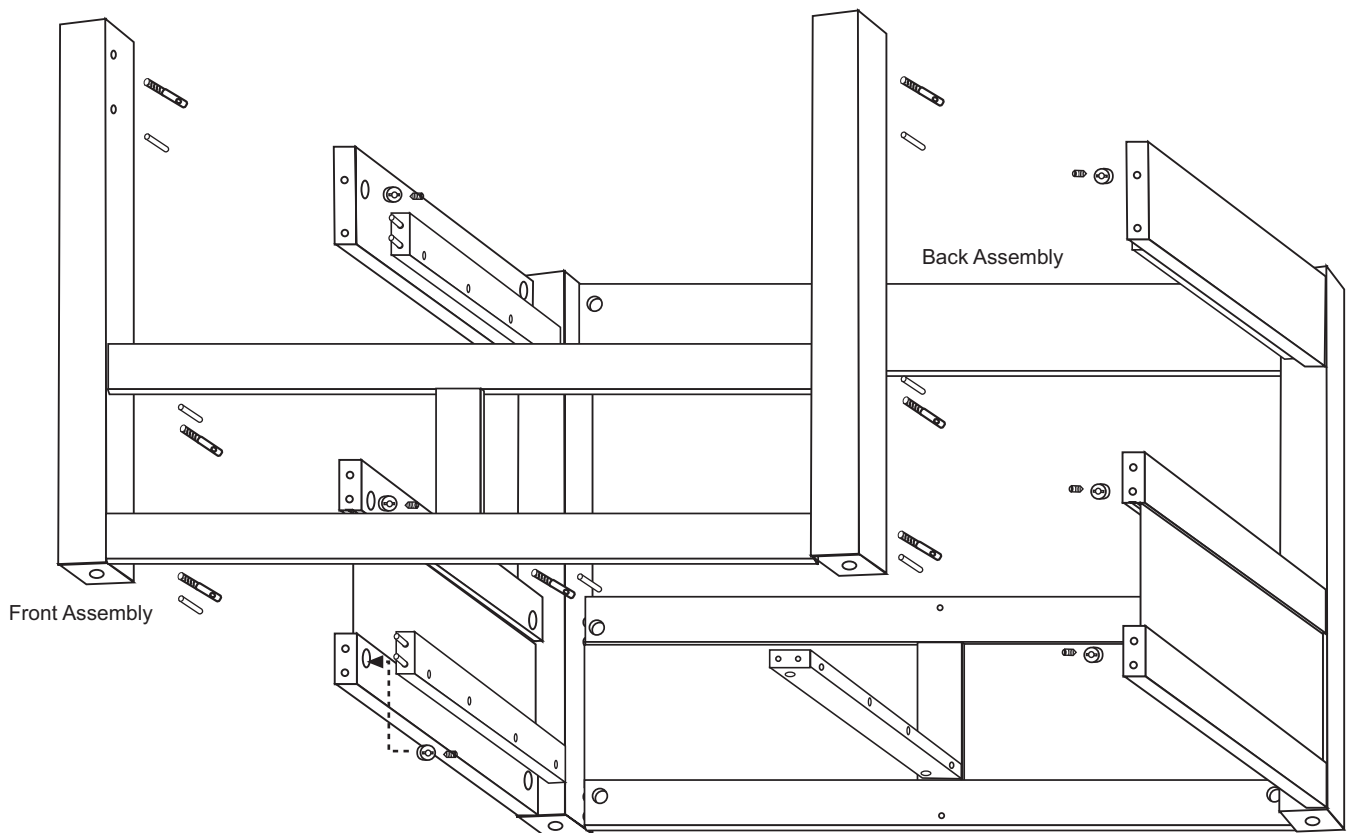
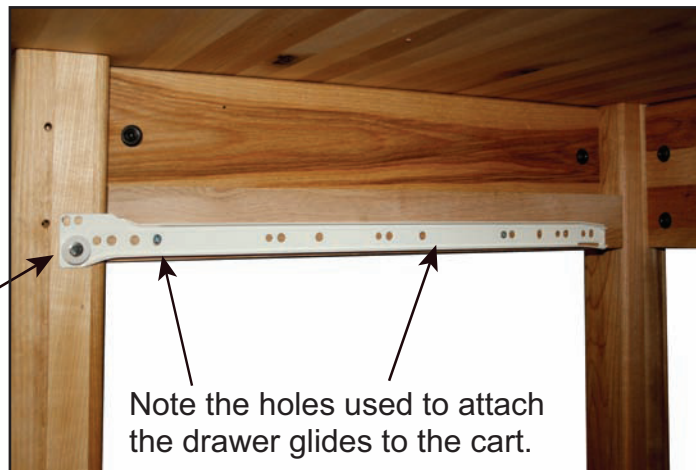
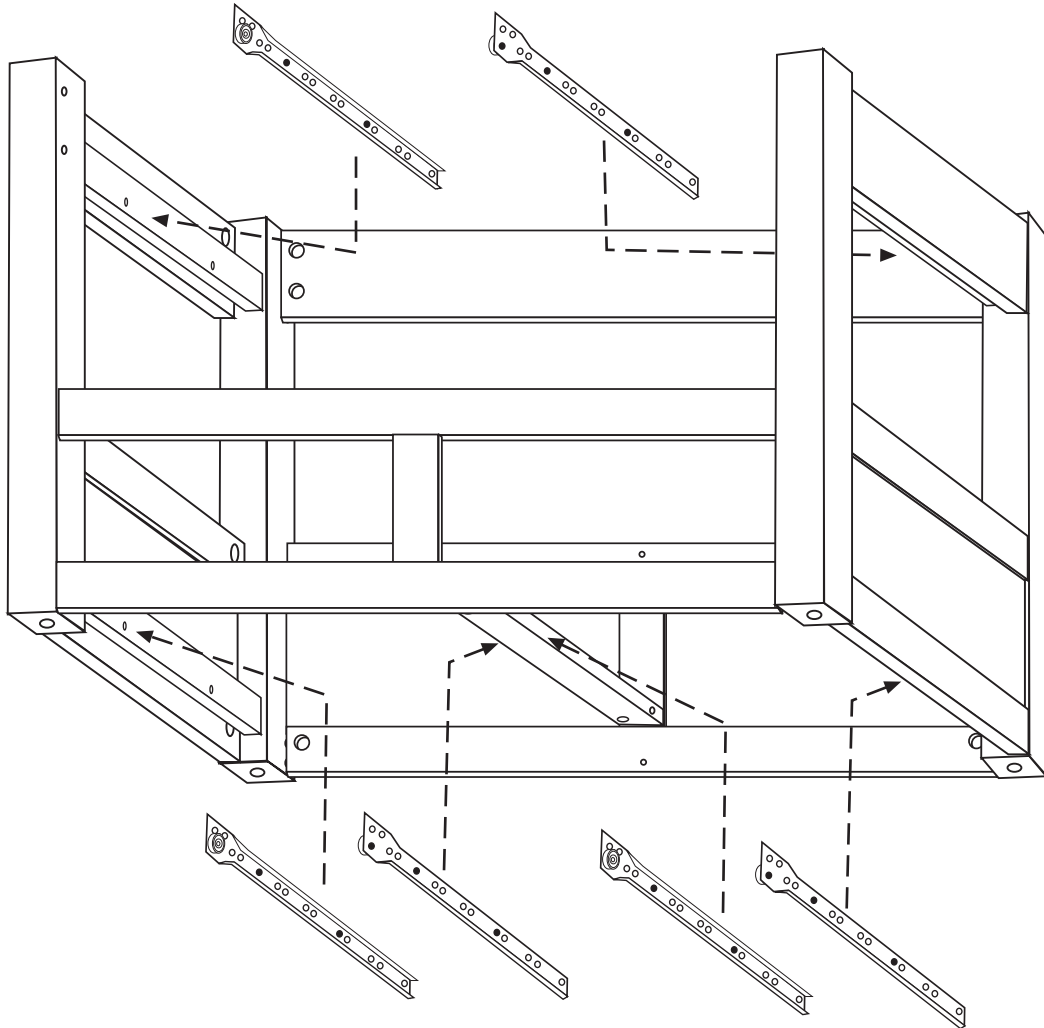

Illustration 4A

STEP 5

ATTACH DRAWER GLIDES

Attach the Cabinet drawer glides for both bottom drawers and the top drawer to the drawer support sticks using the 5/8" #7 screws. Note: refer to the label included with screw pack to make sure the appropriate screws are used for this step.



Glide overlaps leg by 1 1/4"

Note the holes used to attach the drawer glides to the cart.

STEP 6

INSERT SHELF

Make sure 1" Steel Pins were firmly tapped into place in the pilot holes on each of the center braces in previous steps.

Then, take the center shelf and dip it down into the unit, putting one end down near the bottom drawer support stick as shown in Illustration 6A. This will allow the other end to clear the opposite top drawer support stick while resting on the pins in the front and back center braces. Back the shelf up until both ends are above the steel pin supports on each side center brace as shown in Illustration 6B. Then settle the shelf down onto the pins as shown in Illustration 6C.

Straight on view of cart with front cutaway

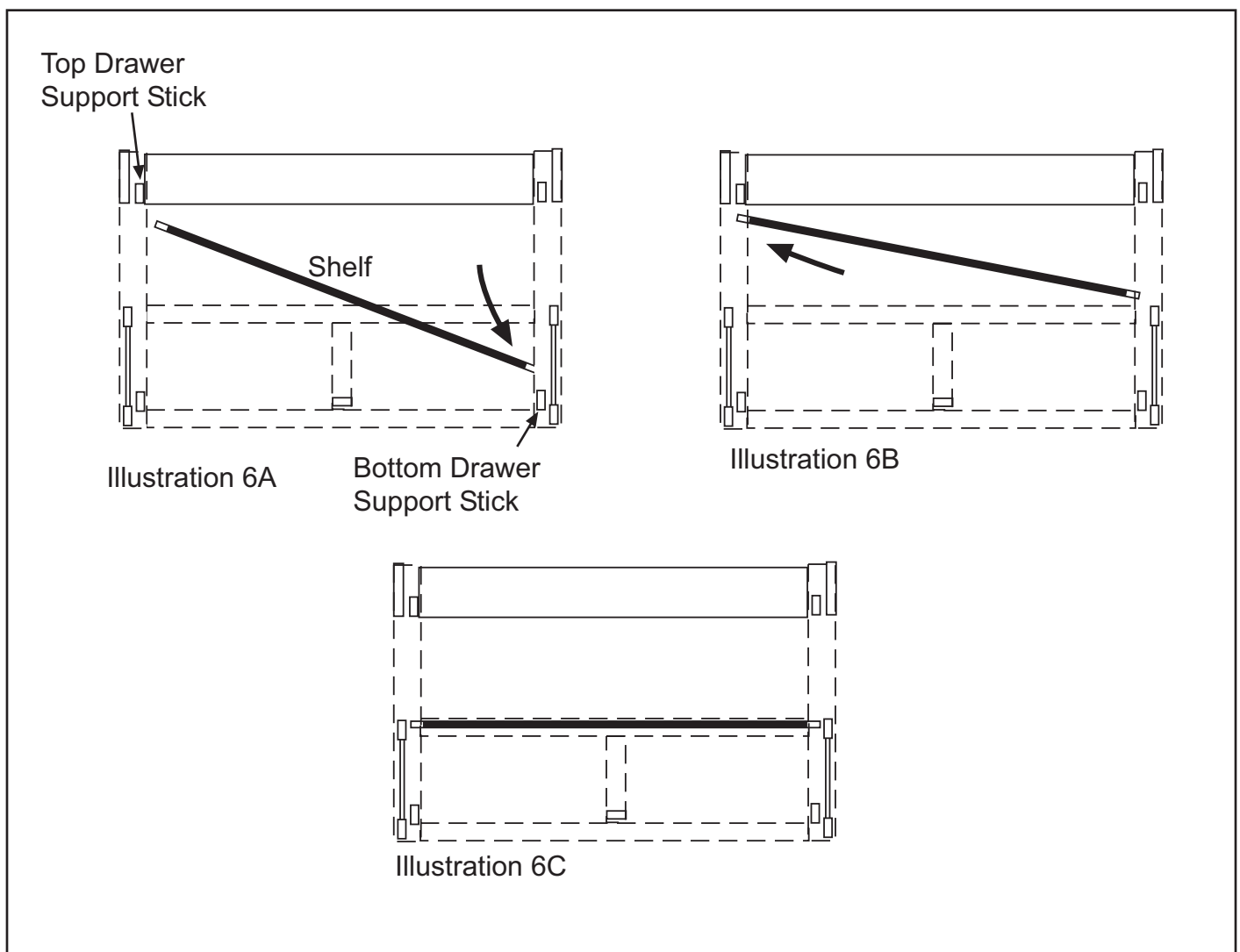

STEP 6

ASSEMBLE DRAWERS

A. Attach the Drawer Back to the Left and Right Drawer Sides with four 1 ¼" #8 Screws. Make sure the slots that run the length of the Sides are aligned with the slot in the Drawer Back to accept the Drawer Bottom.

B. Slide in Drawer Bottom, best side up,

C. Take two (2) Bastion Posts for the top drawer, four (4) Bastion Posts for the bottom drawers, align the threaded ends of the Posts with the post holes located near the ends of the inside Drawer Front. Tighten Posts down until the solid shaft of the Post hits the wood. Back Post out until the hole/screwdriver slot in the end of the Post is parallel and in direct line with the long edges of the Drawer Front.

D. Insert the Bastion Nuts (B-Nuts) into the nut access holes on the inside of the Drawer Sides with the threaded end facing out. Take the Drawer Front and carefully insert the Posts into the ends of the Brace Sides, through the sides of the B-Nut until seated. Push Nut snugly against the wood in the nut access hole toward the Drawer Front. Hole should be slightly off-center toward the Drawer Front. Insert the Set Screw and tighten down. The Drawer Sides should be tight against the Drawer Front.

E. Attach the Drawer Handle with 8-32 Truss-Head screws. Attach the Drawer Glides (left and Right) to the Drawer Sides using two 5/8" #5 Flat Head Screws per glide. Wheels go toward Drawer Back and are up. **DO NOT INSERT DRAWERS INTO CABINET AT THIS TIME.**

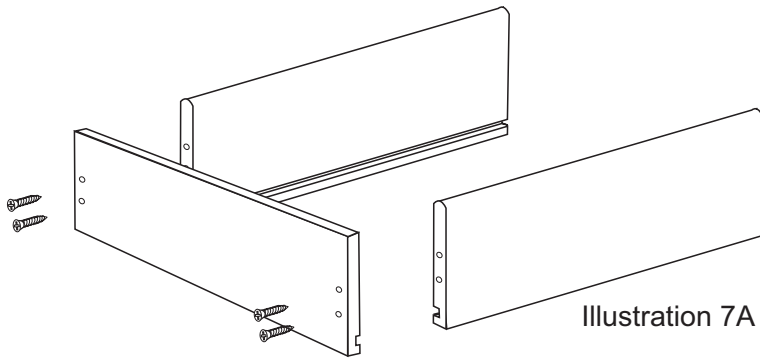

Illustration 7A

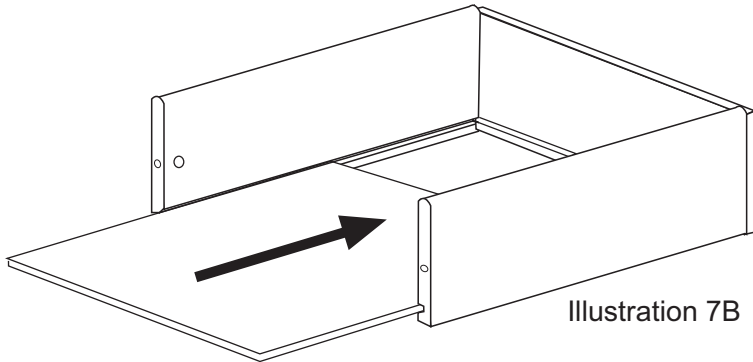

Illustration 7B

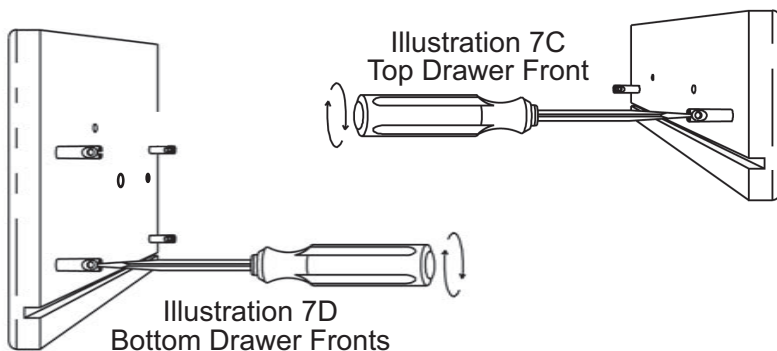

Illustration 7C
Top Drawer Front

Illustration 7D
Bottom Drawer Fronts

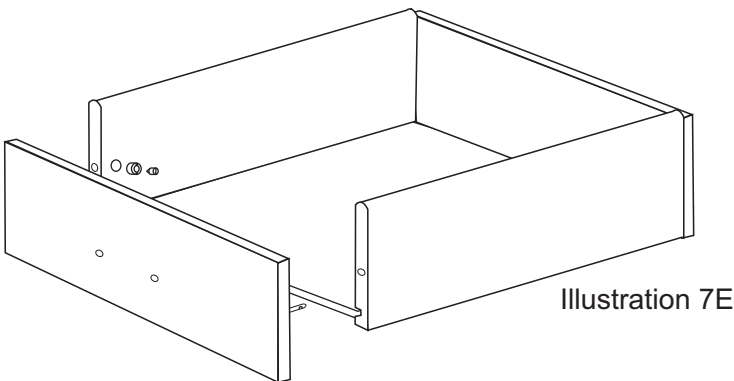

Illustration 7E

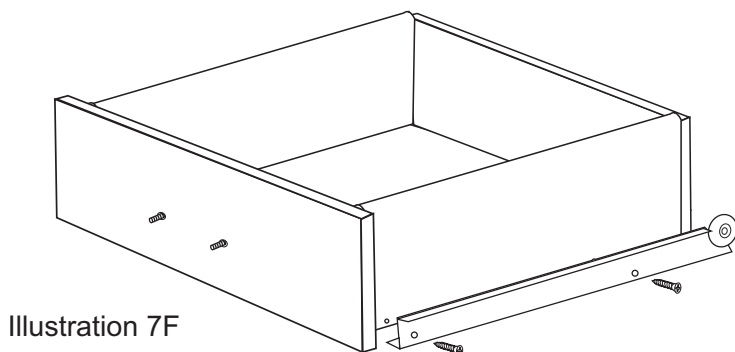

Illustration 7F

STEP 8

ATTACH BUTCHER BLOCK TOP

Attach the 4 L-Brackets to the top side braces with 5/8" # 6 screws. Note the orientation of the L-Brackets in Illustration 8A. The single slot side should attach to the Top Side Braces while the slot and hole side should attach to the Butcher Block Top, also using 5/8" #6 screws.

Note: As the Butcher Block top is heavy and somewhat awkward to maneuver, it is highly recommended to have a friend assist in positioning the Top for attachment.

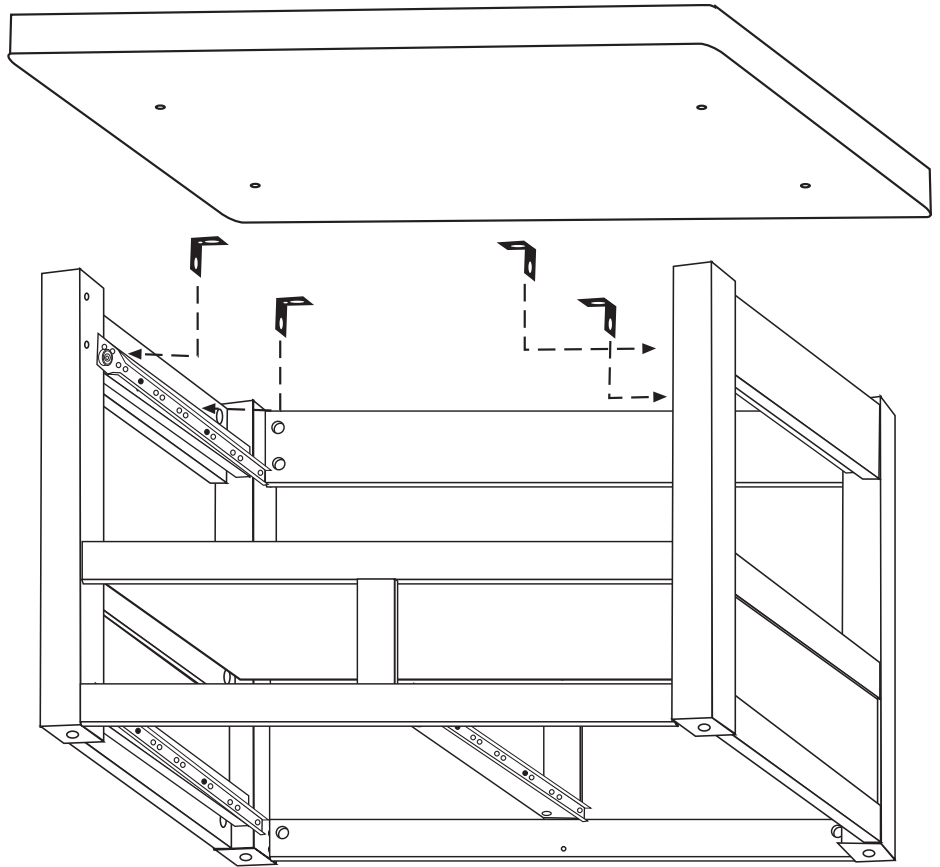

STEP 9

INSERT WHEEL CASTERS

1. Tap the wheel casters into place. Note: It is highly recommended to have a friend assist in setting the cart upright once the casters have been tapped into place.

2. Slide the drawers into place. Your Americana WorkCenter is now ready to use.

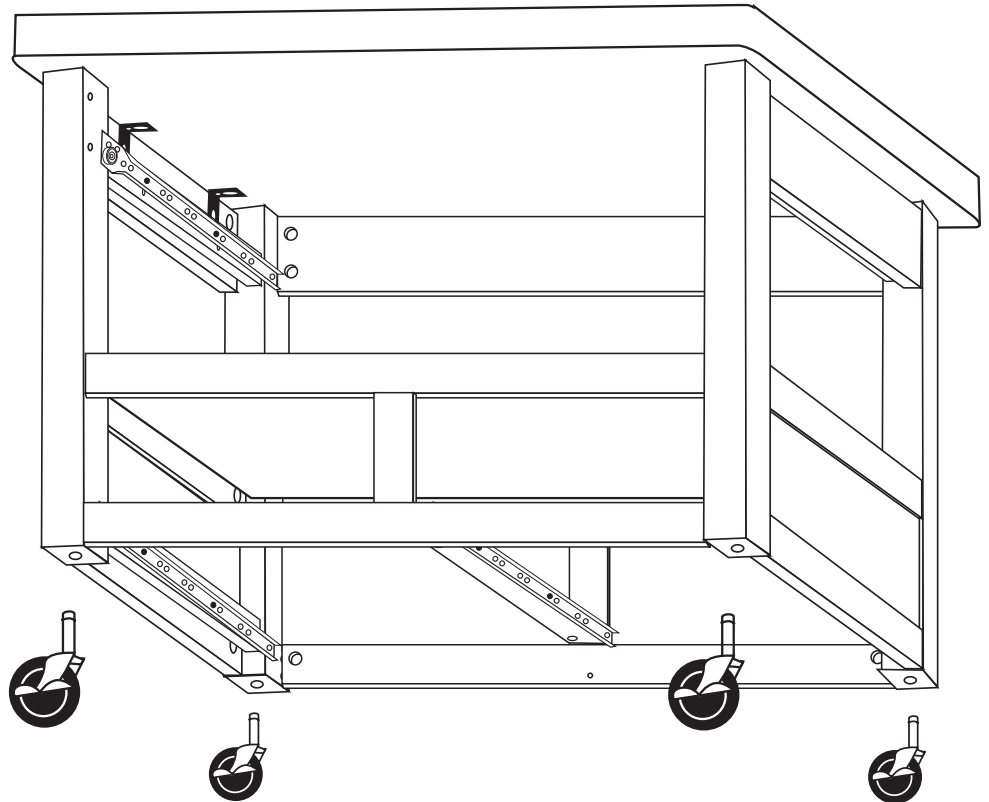



For continued beauty and long life of your Catskill Craftsmen cart, we recommend Catskill Craftsmen's Butcher Block Oil. Our Butcher Block Oil is available directly from Catskill Craftsmen's factory. For one eight ounce (8 fl. oz.) bottle, which is sufficient for two applications, simply send \$7.95 along with the completed coupon to the address below. Visit us online at www.catskillcraftsmen.com to browse our assortment of butcher block care products. Visa and Mastercard are accepted online.



Catskill Craftsmen, Inc.
15 West End Ave.
Stamford, NY 12167-1296



BUTCHER BLOCK OIL COUPON

Please send me _____ # of bottle(s) of the Catskill Craftsmen Butcher Block Oil at \$7.95 per bottle. My check or money order is enclosed for a total of \$_____.

Item code: 1426

Name _____

Address _____

City _____

State _____ Zip _____

Please make checks payable to Catskill Craftsmen Inc.
15 West End Ave., Stamford, NY 12167-1296