

CATSKILL

C R A F T S M E N , I N C .

Assembly Instructions Model 1429

The Europa WorkCenter



GENERAL:

1. You have purchased model 1429.
2. Should you need assistance or need to replace a damaged or missing part simply give us a call M-F at 607-652-7321 from 7:30 am - 4:30 pm EST and we'll send you the prepaid part via UPS usually that same day! You may also email us info@catskillcraftsmen.com.
3. Read the assembly instructions and the enclosed brochure before beginning assembly. Assembly is easy if you read and follow the instructions step by step. See our website for assembly tips and videos: www.catskillcraftsmen.com
4. The only tools needed are a hammer and a screwdriver. A power screwdriver is recommended. Where possible we have packaged some of the screws in separate labeled packages. A friend is recommended to assist with the assembly. Some parts are large and awkward to hold in place.
5. Glides are sometimes pre-packed with screws. There are not used.
6. Instructions (left/right, top/bottom) are given as you face an assembled unit.

CABINET PARTS

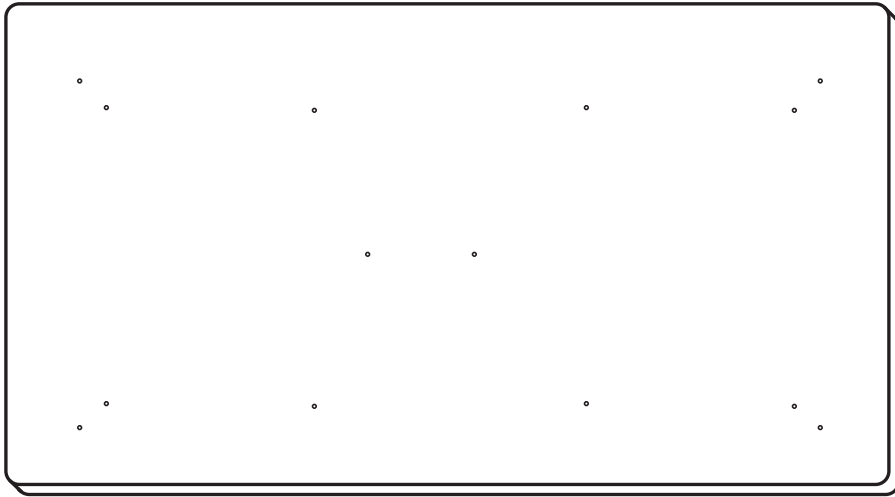

(1) Table Top - 40" x 24" x 2"
PN: TT1429

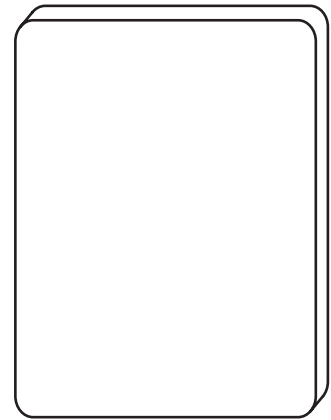

(2) Cutting Board
18" x 14-3/4" x 7/8"
PN: CB1429

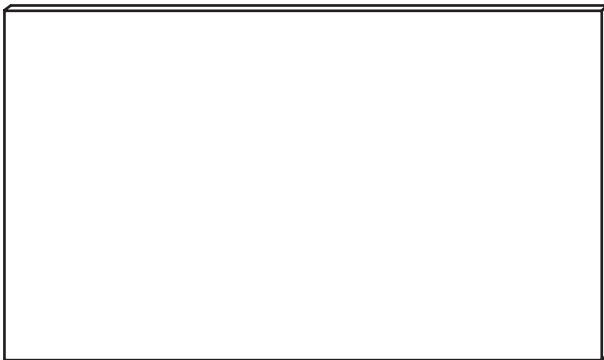

(2) Drawer Bottom - 28-1/8" x 18-1/2" x 5.2mm
PN: DrBot1429

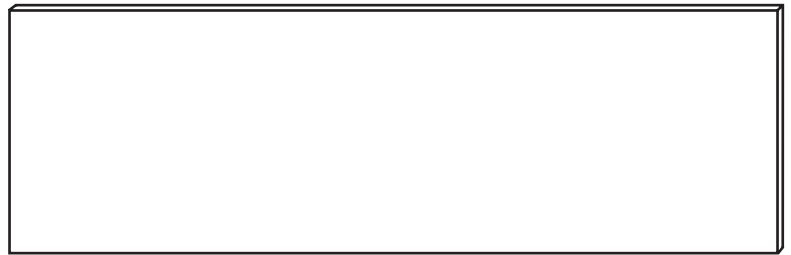

(1) Back Panel Insert - 30" x 9-13/16" x 1/4"
PN: BPInsert1429

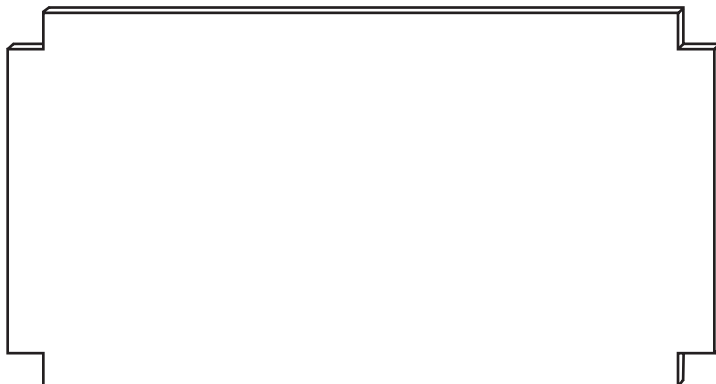

(1) Middle Shelf - 33-5/16" x 18-5/16" x 7/16"
PN: MidS1429



(2) Side Panel Insert
15" x 9-13/16" x 1/4"
PN: SPInsert1429

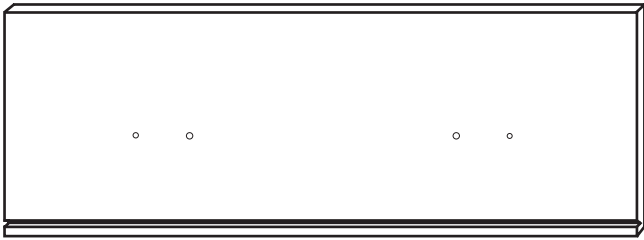

(1) Lower Drawer Front
29-13/16" x 13-3/8" x 3/4"
PN: LDF1429

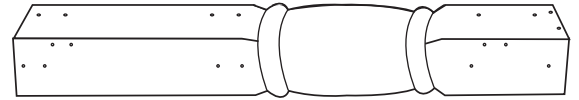

(2) Front Left/Back Right
30" x 3-1/2" x 3-1/2"
PN: FLBRleg1429

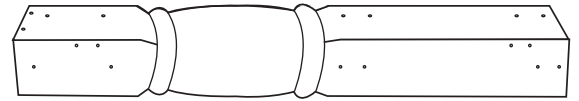

(2) Front Right/Back Left
30" x 3-1/2" x 3-1/2"
PN: FRBLleg1429

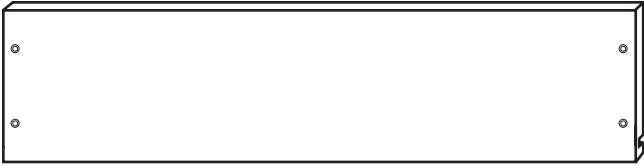

(1) Lower Drawer Back
29" x 8" x 3/4"
PN: LDB1429

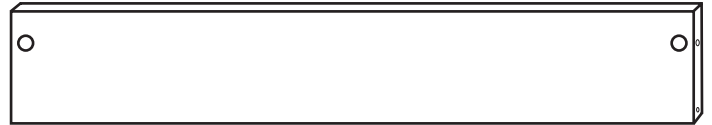

(1) Top Back Brace - 30" x 7-1/2" x 3/4"
PN: TBbrace1429



(1) Lower Right Drawer Side
18" x 8" x 3/4"
PN: LRDS1429

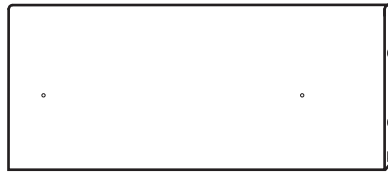

(1) Lower Left Drawer Side
18" x 8" x 3/4"
PN: LLDS1429



(2) Top Side Brace
15" x 6-1/2" x 3/4"
PN: TSB1429



(1) Upper Drawer Front
29-13/16" x 7-3/8" x 3/4"
PN: UDF1429



(4) Mid/Bot Side Brace
15" x 2-1/4" x 3/4"
PN: SB1429

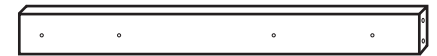

(4) Drawer Glide Support
15" x 1 1/2" x 3/4"
PN: GS1429

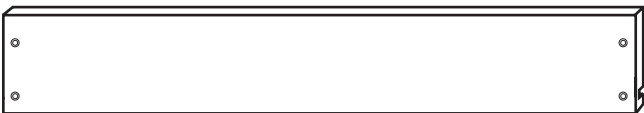

(1) Upper Drawer Back
29" x 5-1/2" x 3/4"
PN: UDB1429

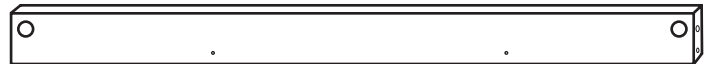

(2) Mid/Top Front Brace - 30" x 2" x 3/4"
PN: FB1429



(2) Mid/Bot Back Brace - 30" x 2" x 3/4"
PN: BB1429



(4) Cutting Board Slats
11 3/4" x 1-9/16" x 1/4"
PN: CBS1429

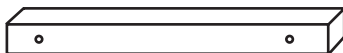

(4) Cutting Board Rails
11 3/4" x 1" x 3/4"
PN: CBR1429



(1) Upper Right Drawer Side
18" x 5-1/2" x 3/4"
PN: URDS1429



(1) Upper Left Drawer Side
18" x 5-1/2" x 3/4"
PN: ULDS1429

HARDWARE



Bastion Post (28)
PN: BPost1429

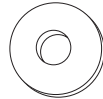

1/2" Flat Washer (8)



3/4" Long 3/16" DIA. Steel Pin (38)
PN: 3/4PIN1429



1" Long 3/16" DIA. Steel Pin (8)
PN: 1PIN1429

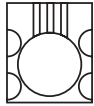

Bastion Barrel Nut (28)
PN: BNut1429

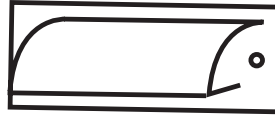

Drawer Handle (4)
PN: 3/4PIN1429



"L" Bracket (4)
PN: LBracket1429



Bastion Set Screw (28)
PN: BSS1429



1 1/4" Phillips Flat Head #8 Screw (10)
PN: 1-1/4PFHS#8-1429

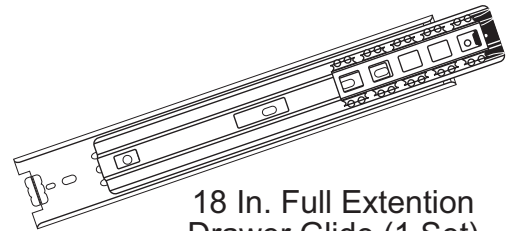

18 In. Full Extension
Drawer Glide (1 Set)



Wooden Cutting
Board Stoppers (2)
PN: WCBS1429

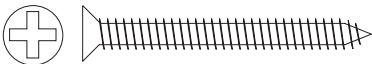

1 3/4" Phillips Flat Head #8 Screw (8)
PN: 1-3/4PFHS#8-1429



3/4" Machine Screw (8)
PN: 3/4MS-1429

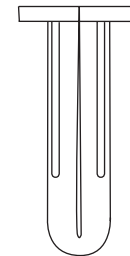

Wheel Insert-1429 (4)

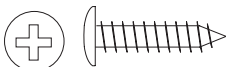

Glide Screws
5/8" Phillips Pan Head #5 Screw (16)
PN: 5/8PPHS#5-1429

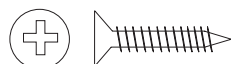

"L" Bracket Screws
5/8" Phillips Flat Head #6 Screw (8)
PN: 5/8PFHS#6-1429

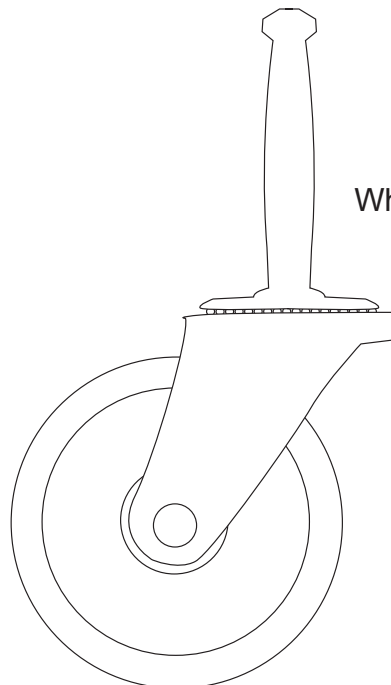

Caster (2)
PN:Caster1429

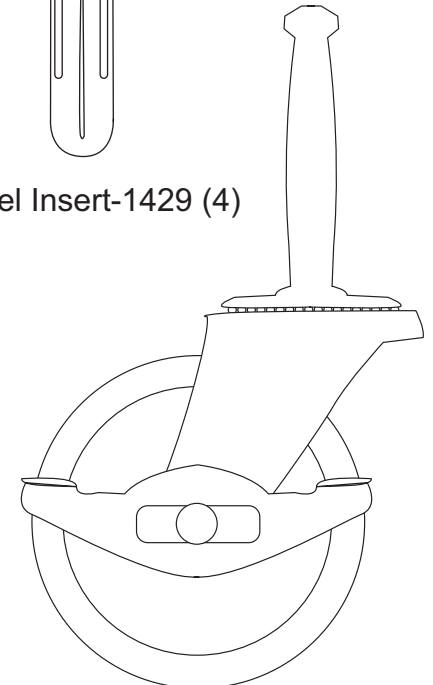

Locking Caster (2)
PN: LCaster1429

TIPS ON HOW THE BASTION FASTENING SYSTEM WORKS

1. The Bastion fastening system consists of a steel post (threaded on one end with a hole through the shaft on the other end); a Barrel Nut (cylindrical barrel-shaped with threaded open end & holes through the sides); and a Set Screw (Phillips slot on one end, pointed on the other)

2. To attach Posts: A) Dip threads of Post in vegetable oil. B) Align threaded end of Post with hole in wood, tap on slotted end with hard hammer until threads enter, then tighten down using a flat head screw driver or the provided allen wrench (See the Illus. Bas. 3 for alternate seating methods). **DO NOT TRY TO HAMMER THE POST ALL THE WAY IN AS IT WILL STRIP THE POST HOLE.** C) When solid shaft of Post hits wood, back out approximately 1/2 turn until the hole in the posts is properly aligned as per step by step directions. For example: the holes in the posts on the inside of the drawer front will be parallel with the long length of the drawer front when properly seated.

3. A) Place a Barrel Nut into the nut access hole, so that the threads in the nut face out. The small notches on either side of the nut opening, indicate the location of the holes through the sides of the nut. B) Insert the posts through the end of the braces (or drawer sides); through the holes in the sides of the nut. When properly aligned, you will see the hole in the post inside the barrel nut. Post hole should be slightly off-center toward the wood.

4. Insert the Set Screw into the threaded end of the nut and tighten down. The tip of the Set Screw will seek the center of the hole in the Post as it is tightened down, forcing the Nut toward the main shaft of the Post. This is what tightens the wooden parts together. Set screws should thread easily – **DON'T CROSS THREAD!** If Set Screw doesn't thread easily, check position of the hole in Post.

5. If the wooden parts are not tight against each other, the Post needs to be screwed a half turn at a time until wood joints are tight.

Illustration Bas. 1

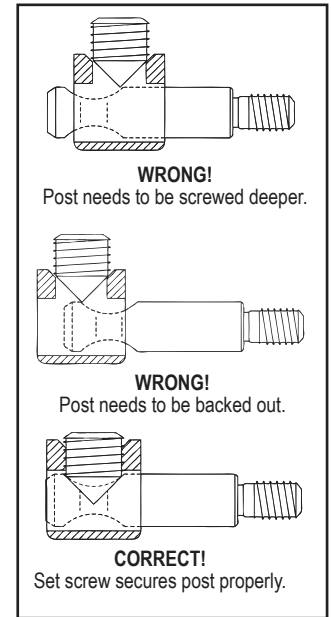

Step 1

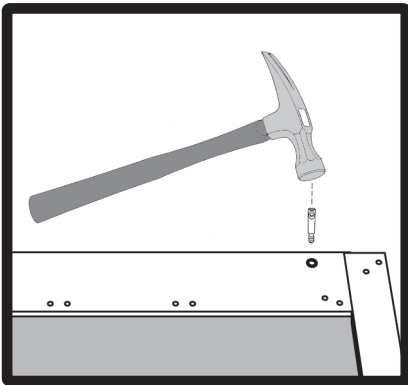
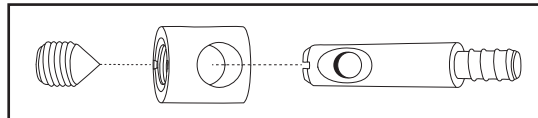
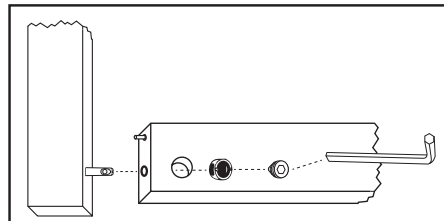

Illustration Bas. 2



Step 2



Allen Wrench Provided

Illustration Bas. 3

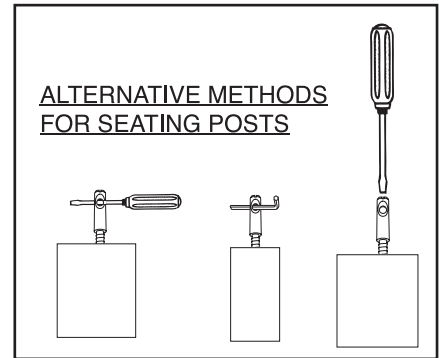

See video on our website!

If you have any questions regarding assembly or missing or damage parts, call our customer support number:

607-652-7321 or 888-732-7321.

Customer Support Hours are 8am-5pm Mon. - Fri. Eastern Time zone.

STEP 1

Back Assembly

1 Front Right/Back left Leg, 1 Front Left/Back Right Leg, 1 Top Back Brace, 2 Middle/Bottom Back Brace, 1 Back Panel Insert.

1. Tap 3/4" pins into the ends of all the braces. The pin goes into the smaller of the two holes.
2. Lay the legs on a flat smooth surface so that the holes are oriented as shown in Illustration 1. Put bastion posts in the center hole third, fifth, and sixth holes from the tops of the legs. The holes in the bastion posts should be oriented as shown in Illustration 1.
3. Attach the Top Back Brace and both the Middle & Bottom Back Braces to one of the legs using barrel nuts and set screws, then slide in the Back Panel Insert into the grooves on the Middle/Bottom back braces.
4. Attach the other leg to the braces using barrel nuts and set screws.

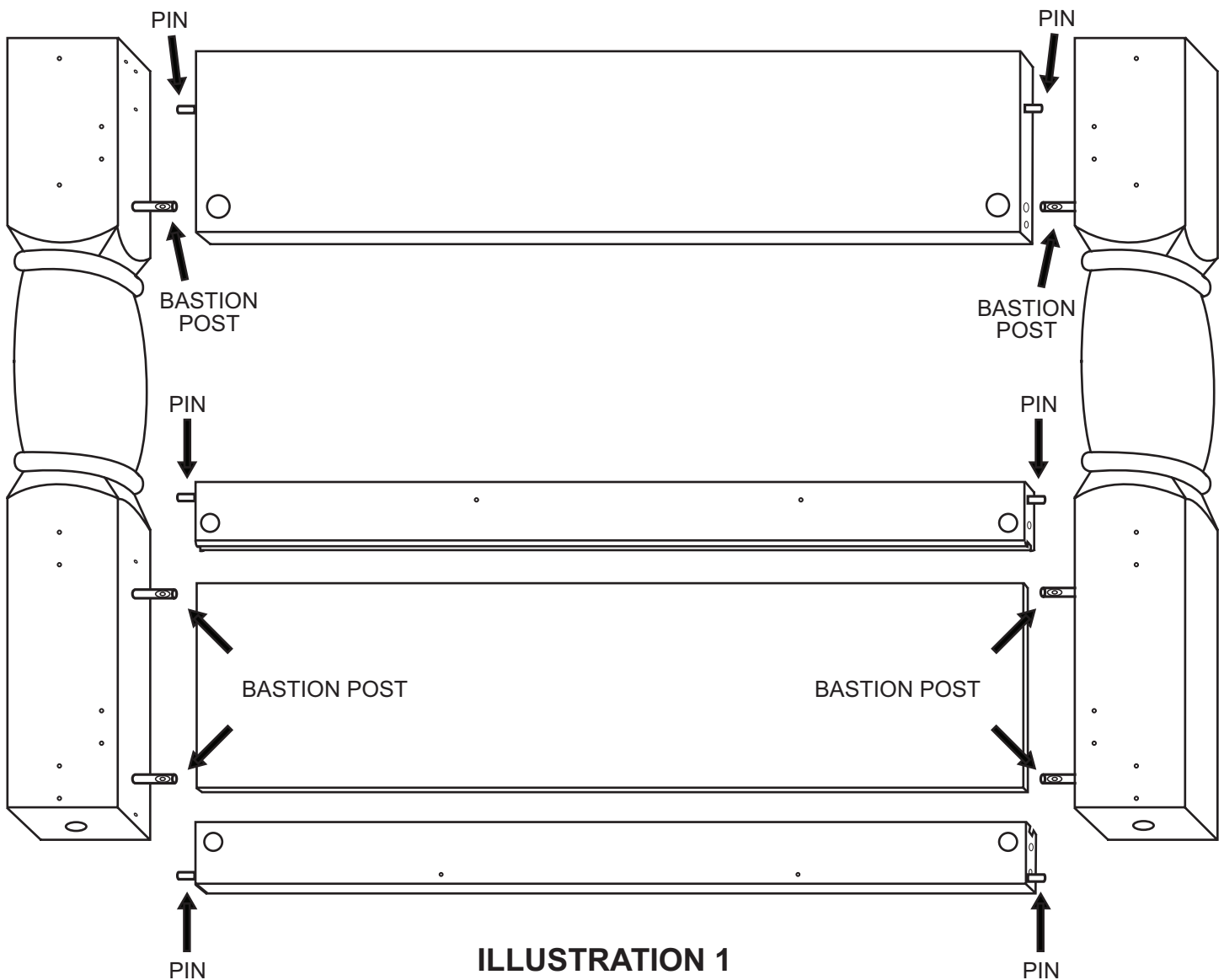

STEP 2

Front Assembly

1 Front Right/Back left Leg, 1 Front Left/Back Right Leg, 2 Mid/Top Front Brace

1. Tap 3/4" pins into the ends of all the braces. The pin goes into the smaller of the two holes.
2. Lay the legs on a flat smooth surface so that the holes are oriented as shown in Illustration 2.
Put bastion posts in the first and fifth holes from the top of the legs. The holes in the bastion posts should be oriented as shown in Illustration 2.
3. Attach both the Mid/Top Front Braces to one of the legs using barrel nuts and set screws.
4. Attach the other Leg to the braces using barrel nuts and set screws.

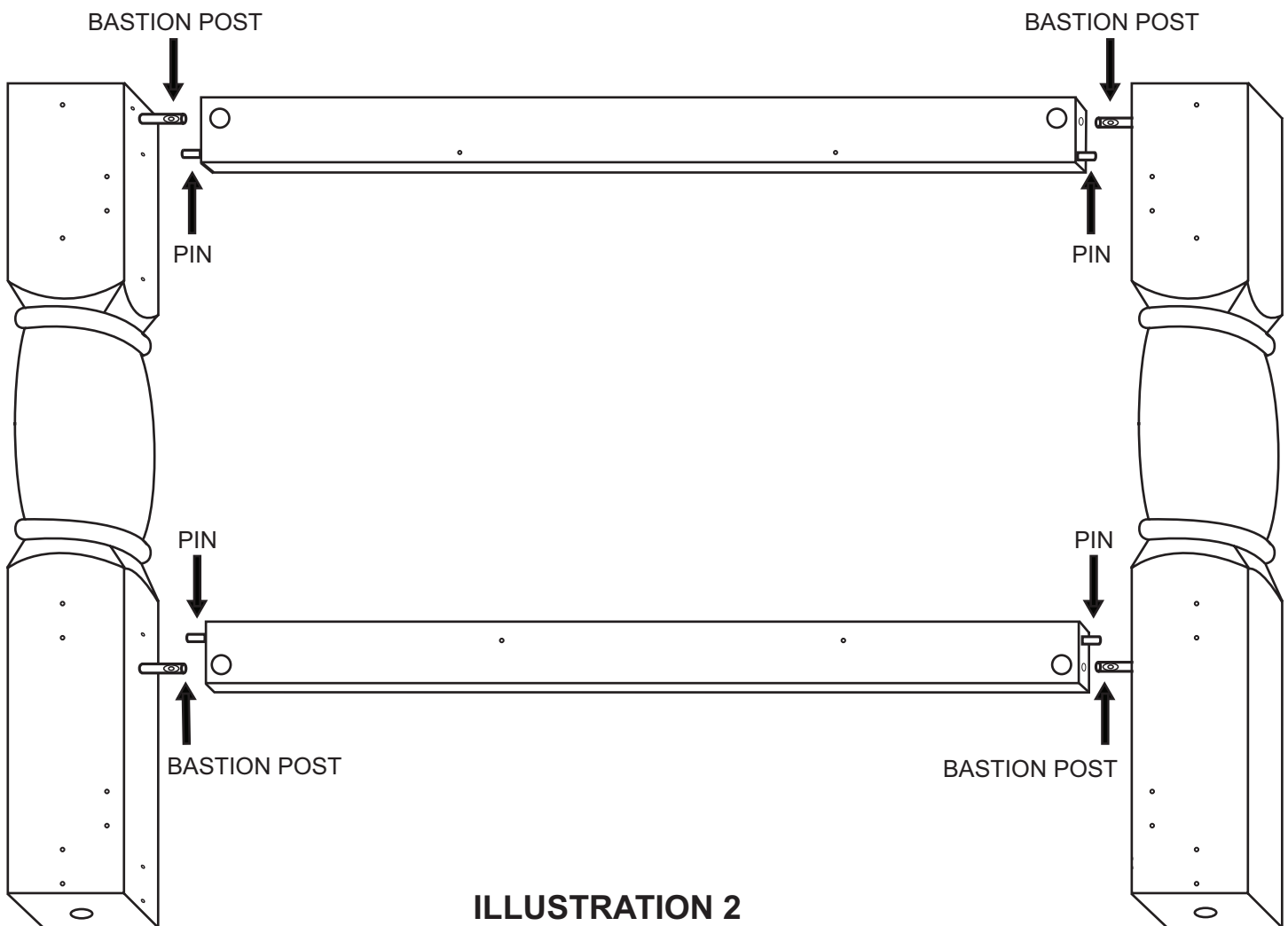

STEP 3

Main Assembly

1 Assembled Back, 1 Assembled Front, 2 Top Side Braces, 4 Mid/Bot Side Braces,
4 Drawer Glide Supports, 2 Side Panel Inserts

1. Lay assembled back unit on its back and put bastion posts in the centered holes second, fourth, and fifth from the top of the legs as shown in Illustration 3.
2. Pound 3/4" pins into the ends of all the braces and Drawer Glide Supports.
3. Attach the Top Side Braces and the Middle & Bottom Side Braces to the legs using barrel nuts and set screws. Then slide the Side Panel Inserts between the Middle & Bottom Side Braces.
4. Now fit the Drawer Glide Supports into place with the 3/4" pins making sure that the holes on the support are on the bottom edge.

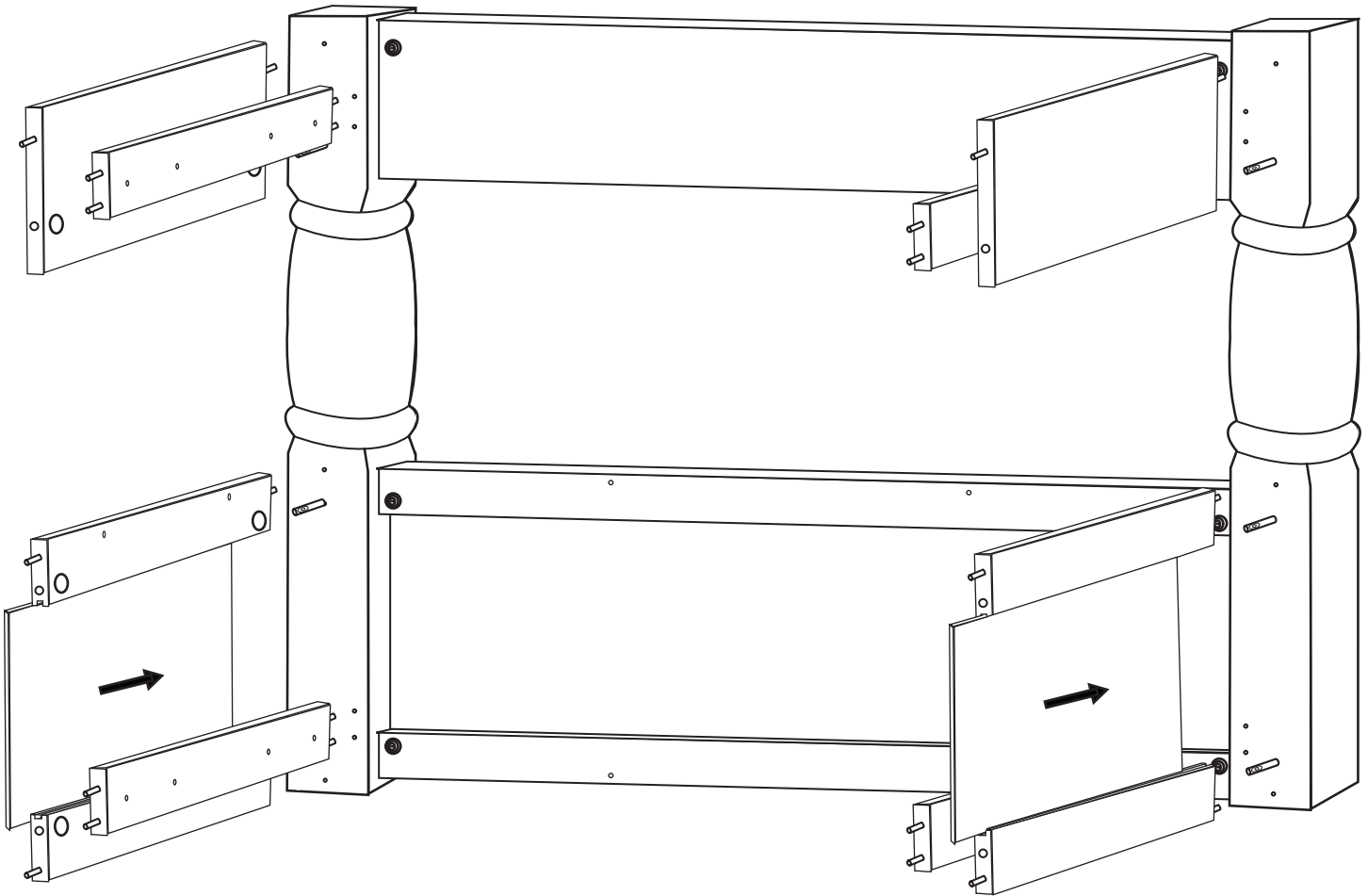

ILLUSTRATION 3

STEP 4

Main Assembly Part 2

1 Assembled Back, 1 Assembled Front

1. With the back assembly from step 3 in the same position, fit the Assembled Front onto the braces, lining up all the pins and bastion posts with holes.
2. Secure the Assembled Front to the braces using barrel nuts and set screws.
3. Tap in the caster sockets with a hammer. Then fit in the casters. Tap them into place with a hammer if necessary.
4. Screw the Drawer Glides to the Drawer Glide Support with 5/8" #6 screws (first remove the glide insert by pressing down on the black tab), line up the holes so that the glide slides out towards the front. The glide should be attached so that it overlaps the back leg by about 1/2", and overlaps the front leg by 2 1/4".

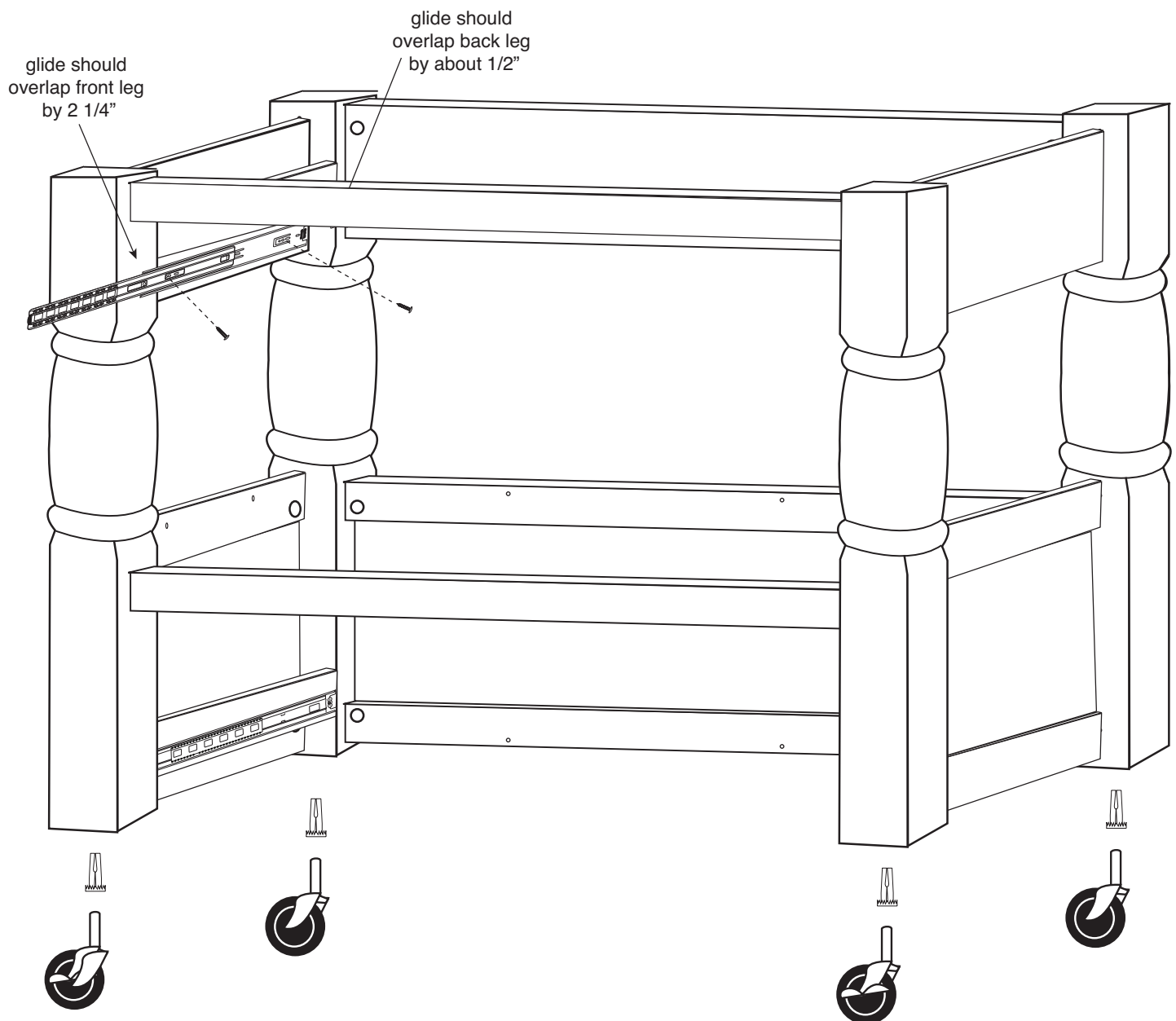

ILLUSTRATION 4

STEP 5

Drawer Assembly

1 Lower Drawer Front, 1 Upper Drawer Front, 1 Upper Left Drawer Side, 1 Upper Right Drawer Side, 1 Lower Left Drawer Side, 1 Lower Right Drawer Side, 1 Lower Drawer Back, 1 Upper Drawer Back, 2 Drawer Bottoms, 4 Handles, 8 Machine Screws

1. Attach Drawer Back to Drawer Sides using 1-1/4" Phillips Flat Head #8 screws.
2. Then insert Drawer Bottom into slots.
3. Put bastion posts into Drawer Front & secure to Drawer Sides using barrel nuts & set screws.
4. Attach handles using 3/4" panhead machine screws use washers if needed.
5. Attach the Glide inserts to the drawer sides using 5/8" Phillips Pan Head #6 Screws.

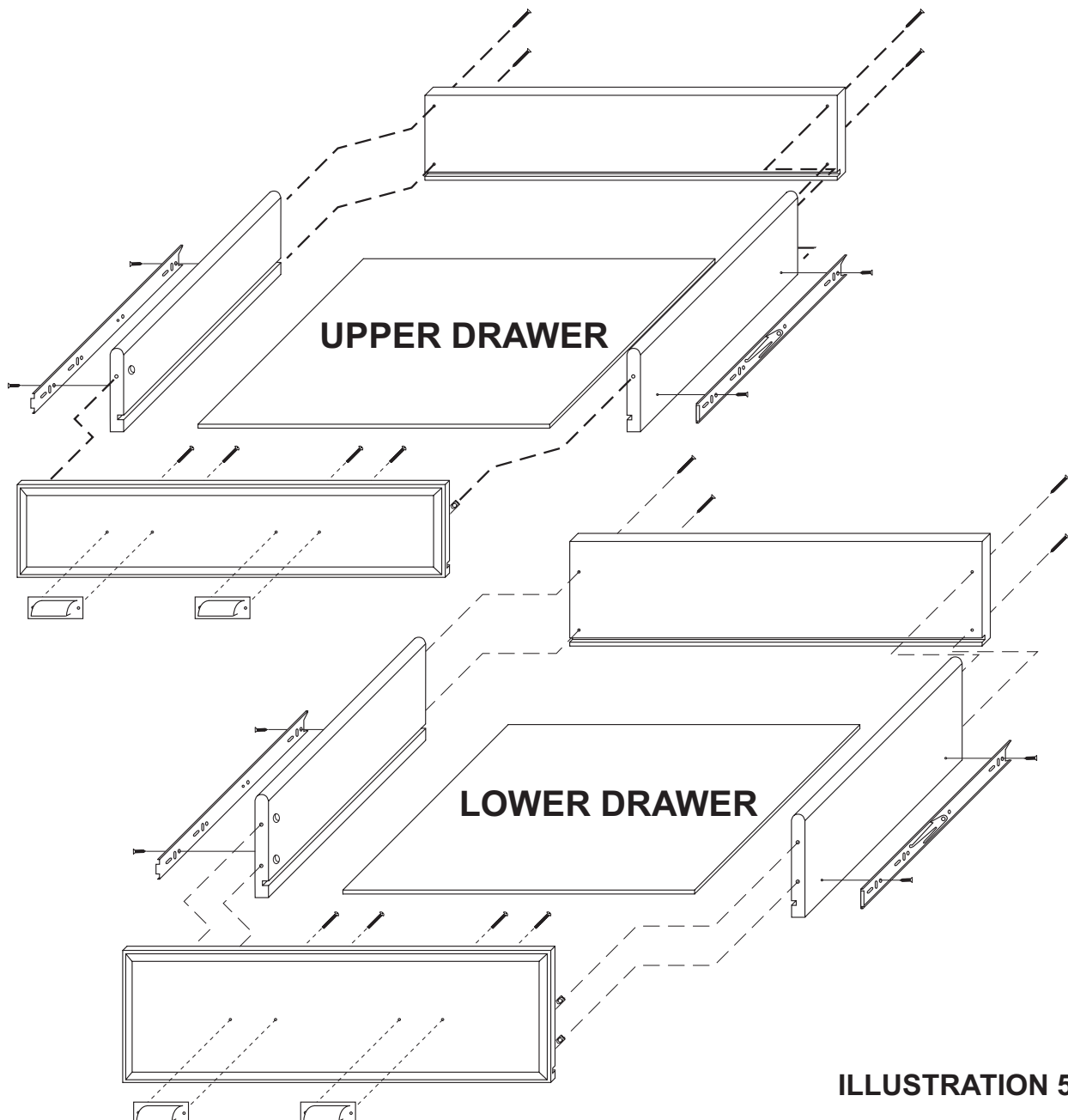

ILLUSTRATION 5

STEP 6

Top Assembly

1 Table Top, 4 Cutting Board Slats, 4 Cutting Board Rails

1. Lay the Table Top upside-down on a smooth flat surface and attach the Cutting Board Rails & Slats as shown in illustration 8 using 1 3/4" #8 screws.
2. Attach the Cutting Board Stoppers to the center holes on the Table Top using 1 1/4" #8 screws.
3. Then attach the "L" Brackets to the top using 5/8" #6 screws. Attach "L" Brackets to the table top using the round hole, not the slots.

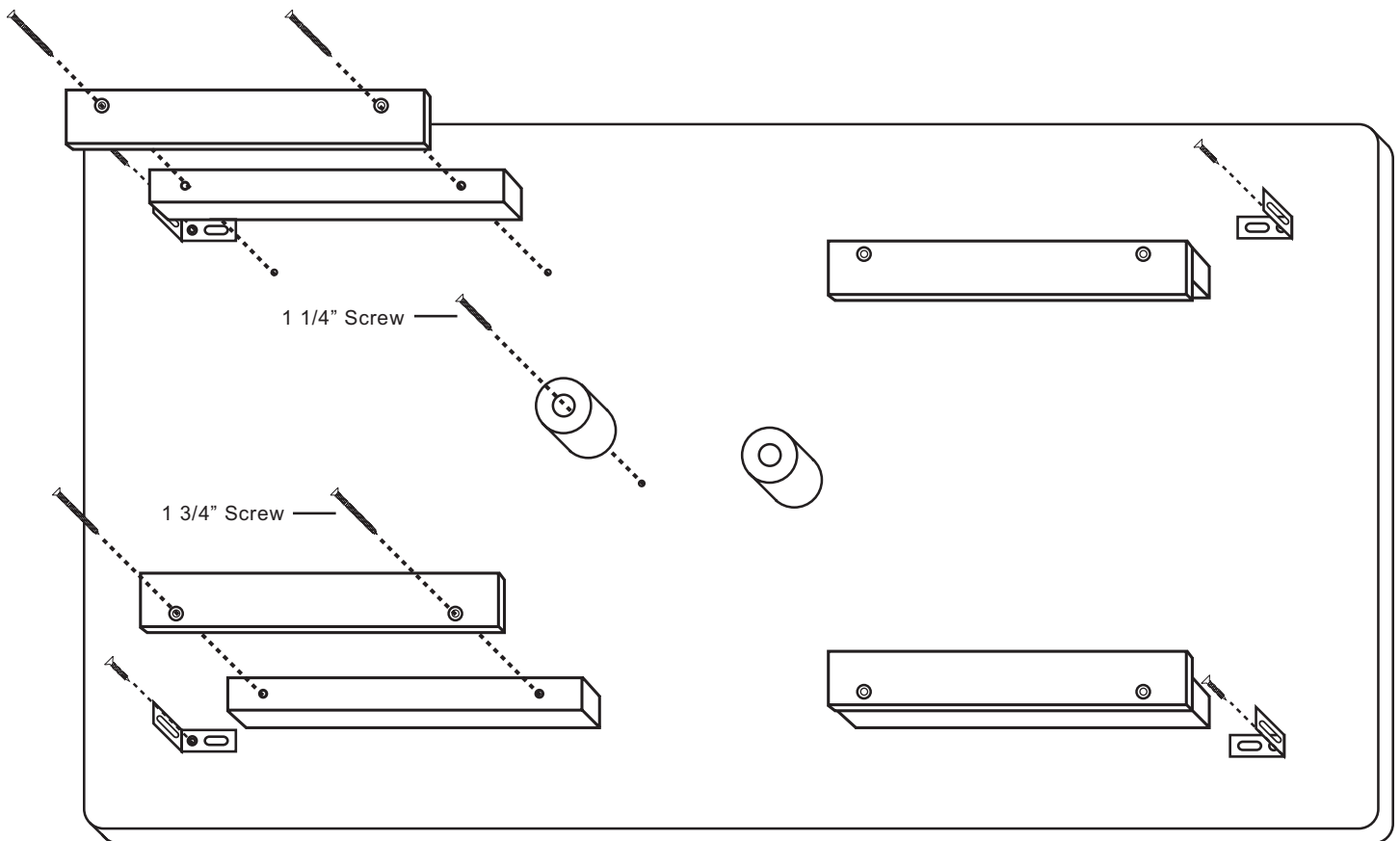

ILLUSTRATION 6

STEP 7

Finishing Touches

1 Main Assembly, 1 Assembled Upper Drawer, 1 Assembled Lower Drawer, 1 Assembled Top, 1 Middle Shelf

1. Now tap in 1" pins into the middle braces with a hammer and fit the middle shelf on the top of the pins.
2. Fit the Top into place then secure it to legs using 5/8" #6 screws through the "L" Brackets. (Note: top drawer must be removed to allow for attaching "L" brackets)
3. Attach the drawers to the cart by sliding them into the Glide Rails.

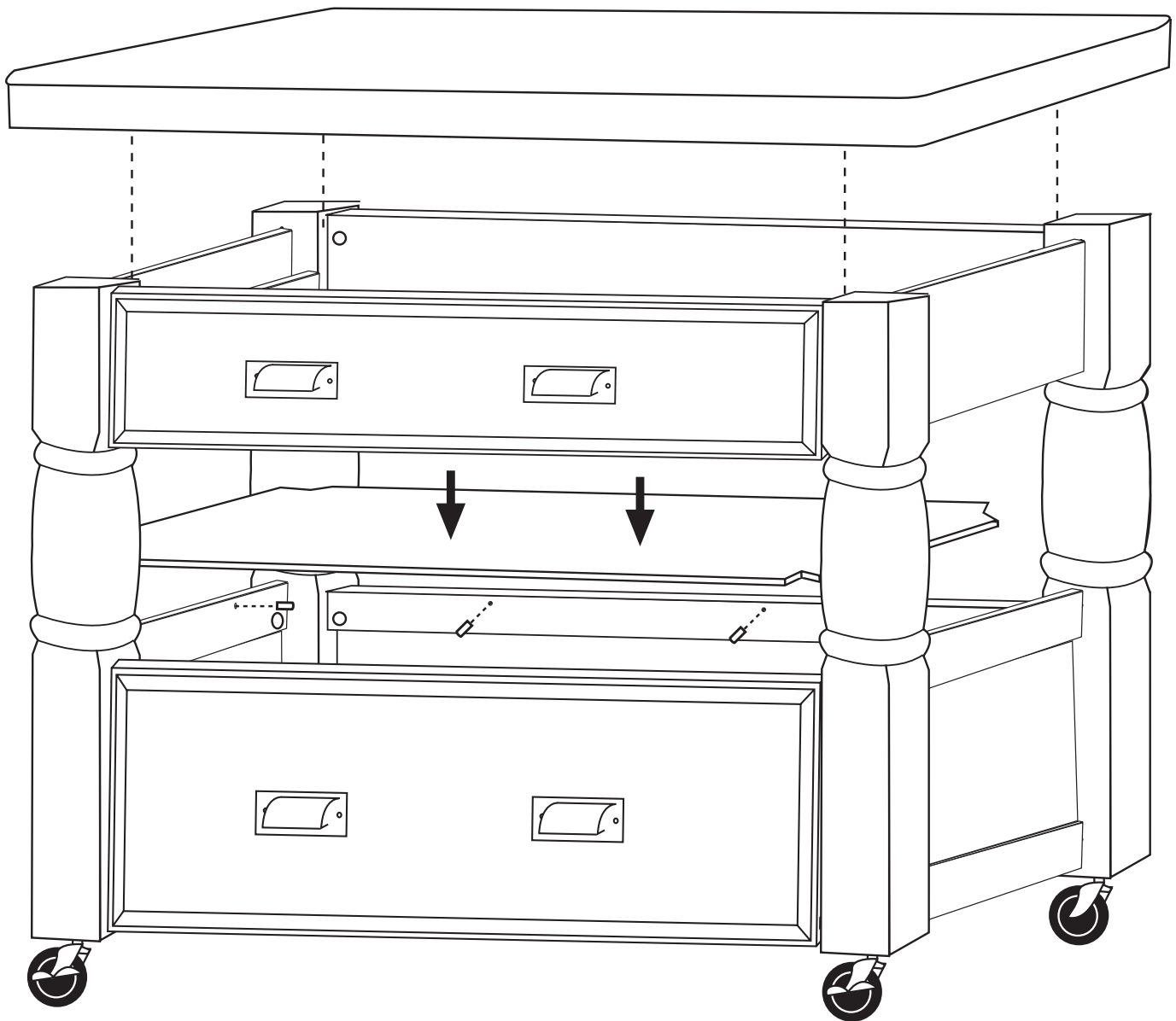

Note: It may be necessary to remove the cutting board rails & slats to fully tighten the L-Bracket screws.

ILLUSTRATION 7

STEP 8

Finishing Touches Part 2

1 Main Assembly, 2 Cutting Boards

1. Slide the 2 Cutting Boards into the sides to complete the assembly process



ILLUSTRATION 8



For continued beauty and long life of your Catskill Craftsmen cart, we recommend Catskill Craftsmen's Butcher Block Oil. Our Butcher Block Oil is available directly from Catskill Craftsmen's factory. For one eight ounce (8 fl. oz.) bottle, which is sufficient for two applications, simply send \$7.95 along with the completed coupon to the address below. Visit us online at www.catskillcraftsmen.com to browse our assortment of butcher block care products. Visa and Mastercard are accepted online.



Catskill Craftsmen, Inc.
15 West End Ave.
Stamford, NY 12167-1296



BUTCHER BLOCK OIL COUPON

Please send me _____ # of bottle(s) of the Catskill Craftsmen Butcher Block Oil at \$7.95 per bottle. My check or money order is enclosed for a total of \$_____.

Item code: 1429

Name _____

Address _____

City _____

State _____ Zip _____

Please make checks payable to Catskill Craftsmen Inc.
15 West End Ave., Stamford, NY 12167-1296