

# CATSKILL

C R A F T S M E N , I N C .

## **Assembly Instructions** **Model 2008**

### *The Grand Island with Wine Rack*



#### **GENERAL:**

1. Should you need assistance or need to replace a damaged or missing part simply give us a call M-F at 607-652-7321 from 7:30 am - 4:30 pm EST and we'll send you the prepaid part via UPS usually that same day! You may also email us [info@catskillcraftsmen.com](mailto:info@catskillcraftsmen.com).
2. Read the assembly instructions and the enclosed brochure before beginning assembly. Assembly is easy if you read and follow the instructions step by step. See our website for assembly tips and videos.
3. Tools required: Phillips screwdrivers, medium and small; medium flat blade screwdriver and a hammer.
4. This unit uses the Bastion System; a simple yet rugged compression fastening system. We have a video online at [www.catskillcraftsmen.com](http://www.catskillcraftsmen.com) illustrating the proper installation of this system.
5. Directions (left/right, front/back) are given as facing the front of an assembled upright unit.

# CABINET PARTS MODEL 2008



Drop Leaf (1)  
P/N DL-2007

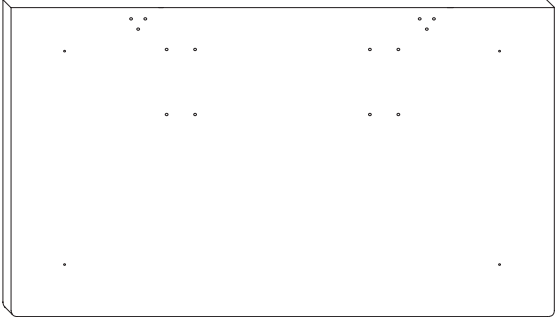

Table Top (1)  
P/N TT-2007



Drawer Front (1)  
P/N DF-2007  
21 15/16 x 9 x 3/4



Wine Rack Pipes (7)  
P/N WRP-2008  
15 7/8 x 5/8

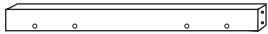

Glide Support Braces (2)  
P/N GS-2007  
13 x 2 x 3/4

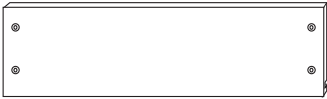

Drawer Back (1)  
P/N DBK-2007  
21 1/8 x 7 x 3/4



Drawer Side Left (1)  
P/N DS-2007L  
14 x 7 x 3/4



Drawer Side Right (1)  
P/N DS-2007R  
14 x 7 x 3/4

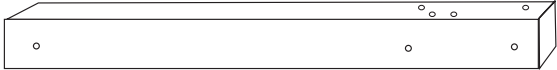

Front Right/Back Left Legs (2)  
P/N L-2007FR/BL



Front Left/Back Right Legs (2)  
P/N L-2007FL/BR

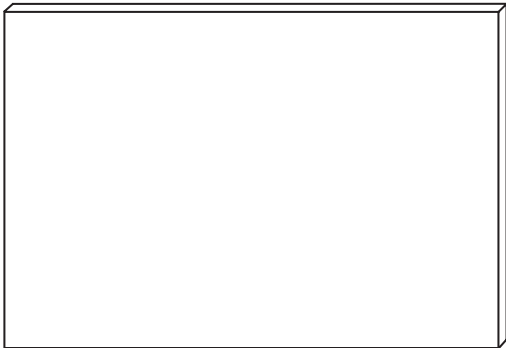

Drawer Bottom (1)  
P/N DBOT-2007  
20 1/4 x 14 5/8 x 5.2 mm



Top Back Brace (1)  
P/N B-2007/TB  
22 1/8 x 7 3/4 x 3/4



Wine Rack Braces (2)  
P/N WRB-2008  
22 1/8 x 1 1/2 x 3/4



Top Side Braces (2)  
P/N B-2007/TS  
13 x 9 x 3/4

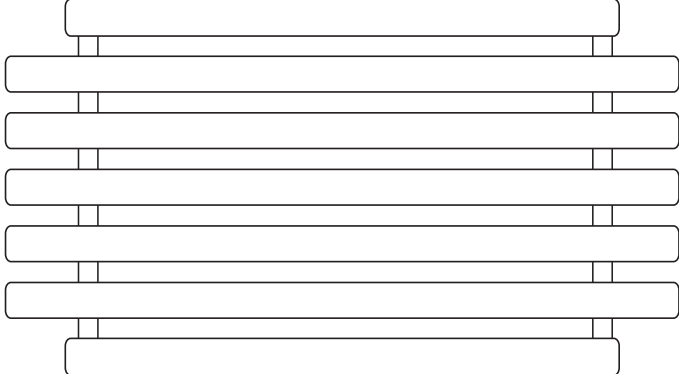

Shelf (1)  
P/N SS-2007

# HARDWARE MODEL 2008



5/8" Phillips Flat Head #8 Screw (26)

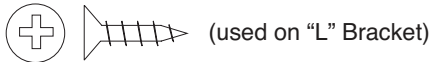

5/8" Phillips Flat Head #6 Screw (8)

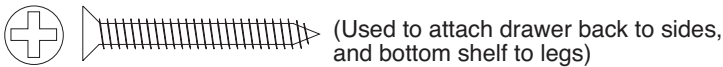

1 1/4" Phillips Flat Head #8 Screw (8)



3/4" Long 3/16" DIA. Steel Pin (16)

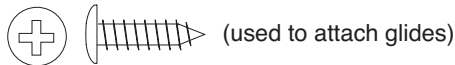

7/16" Pan Head #6 Screw (8)



Bastion Post (16)



Bastion Set Screw (16)

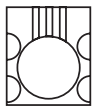

Bastion Barrel Nut (16)

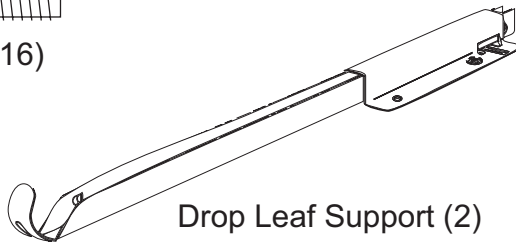

Drop Leaf Support (2)

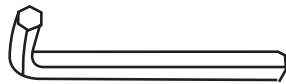

Allen Wrench

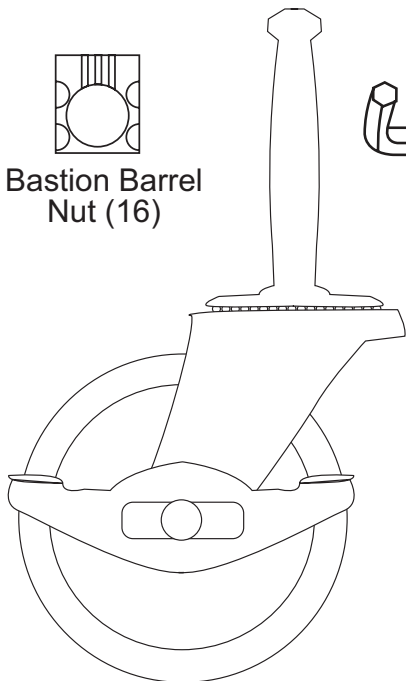

Locking Wheel Caster (2)

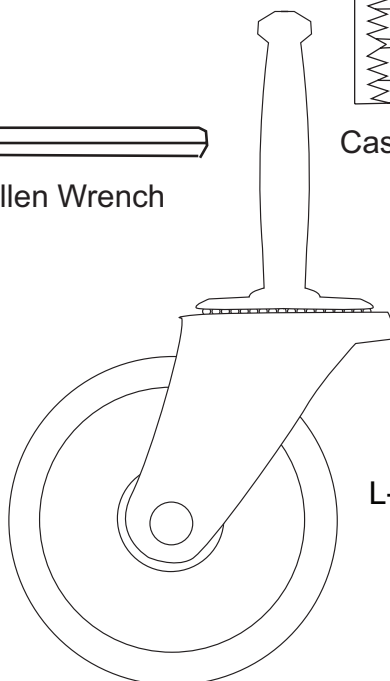

Non-Locking Wheel Caster (2)

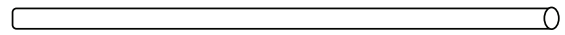

DRAWER HANDLE - 17 7/8" CHROME TUBE SET (1)

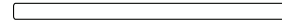

SIDE HANDLE - 13" CHROME TUBE SET (2)

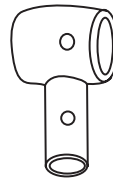

Pipe Holder (6)



End Caps (6)



Standoffs (6)



Set Screw (12)



Towel Bar Post (6)

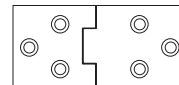

Hinge (3)

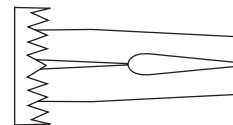

Caster Socket (4)

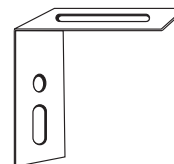

L-Bracket (4)

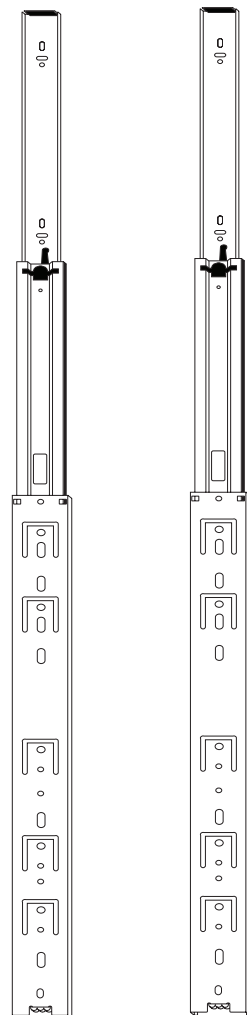

14" FULL EXTENSION GLIDE SET (1)  
P/N GLIDE - 2007

# TIPS ON HOW THE BASTION FASTENING SYSTEM WORKS

1. The Bastion fastening system consists of a steel post (threaded on one end with a hole through the shaft on the other end); a Barrel Nut (cylindrical barrel-shaped with threaded open end & holes through the sides); and a Set Screw (Phillips slot on one end, pointed on the other)

2. To attach Posts: A) Dip threads of Post in vegetable oil. B) Align threaded end of Post with hole in wood, tap on slotted end with hard hammer until threads enter, then tighten down using a flat head screw driver or the provided allen wrench (See the Illus. Bas. 3 for alternate seating methods). **DO NOT TRY TO HAMMER THE POST ALL THE WAY IN AS IT WILL STRIP THE POST HOLE.** C) When solid shaft of Post hits wood, back out approximately ½ turn until the hole in the posts is properly aligned as per step by step directions. For example: the holes in the posts on the inside of the drawer front will be parallel with the long length of the drawer front when properly seated.

3. A) Place a Barrel Nut into the nut access hole, so that the threads in the nut face out. The small notches on either side of the nut opening, indicate the location of the holes through the sides of the nut. B) Insert the posts through the end of the braces (or drawer sides); through the holes in the sides of the nut. When properly aligned, you will see the hole in the post inside the barrel nut. Post hole should be slightly off-center toward the wood.

4. Insert the Set Screw into the threaded end of the nut and tighten down. The tip of the Set Screw will seek the center of the hole in the Post as it is tightened down, forcing the Nut toward the main shaft of the Post. This is what tightens the wooden parts together. Set screws should thread easily – **DON'T CROSS THREAD!** If Set Screw doesn't thread easily, check position of the hole in Post.

5. If the wooden parts are not tight against each other, the Post needs to be screwed a half turn at a time until wood joints are tight.

Illustration Bas. 1

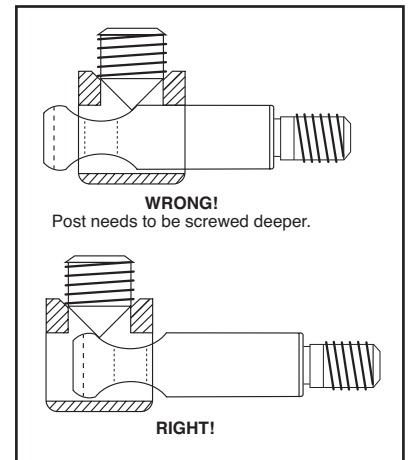
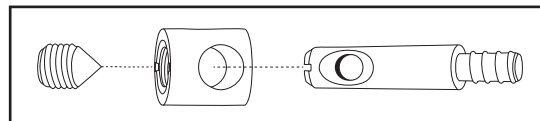
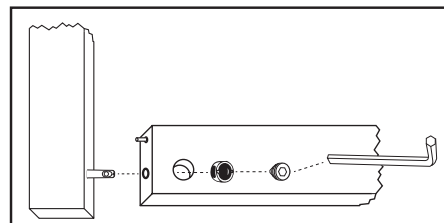

Illustration Bas. 2



Step 2



Allen Wrench Provided

Illustration Bas. 3

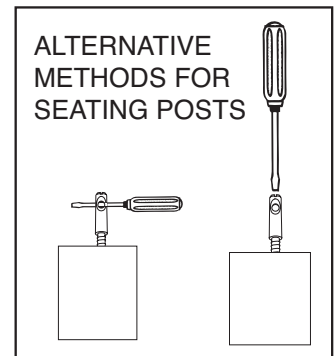

Step 1

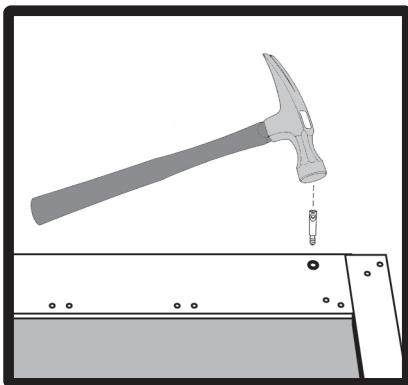

See video on our website!

If you have any questions regarding assembly or missing or damaged parts, call our customer support number:

607-652-7321 or 888-732-7321.

# STEP 1

## ASSEMBLE SIDE PANELS

A. Each side panel consists of two (2) legs, one (1) top side brace and one (1) Glide Support Brace. When assembled, diagonal legs will be the same (i.e. Front Right/Back Left & Front Left/Back Right). Side panels are identical when assembled - the Drawer Glides will determine left and right sides.

B. Take each of the 4 legs and install two (2) Bastion Posts per leg, on the side of the leg which also has two (2) pin holes for the Glide Support Sticks. Locate post holes. Tap Posts in with hammer until threads engage wood; turn Posts down until the solid shaft hits the wood (All threads are into wood), then back Posts out until the holes in the Posts are perpendicular to the long length of the leg (about 1 full turn).

C. Lay out Front Left leg and one (1) top side brace as in Illustration 1A. Note the two pilot holes for the L-Brackets are along the top inside of the top side brace.

D. Take the top side brace and drop two barrel-shaped bronze bastion nuts into the nut access holes as in illustration 1A. Threaded end-of the nuts face out. Insert front left leg posts into the holes in the ends of the brace, through the side of the barrel nuts, until the holes in the posts can be seen through the threaded end of the nuts. Insert the Set Screws into the nuts and tighten down. The tip of the set screw will seek the center of the bastion post as it is tightened, leaving a tight joint. If the joint is loose, check to make sure the set screw is not cross-threaded or that the post is out too far (not threaded into leg deep enough.) See previous page for Bastion illustrations for clarification of assembly or view our instructional video online: [www.catskillcraftsmen.com](http://www.catskillcraftsmen.com).

E. Insert two 3/4" pins into each end of the glide support brace. Position brace such that the pilot holes for attaching the glide are towards the bottom edge. Insert brace pins into the holes on the inside of the left front leg as in illustration 1B (4 pilot holes out) with pilot holes off-center toward the bottom of the leg.

F. Attach Back Left leg in same manner as in illustration 1C.

G. Repeat for other side panel.

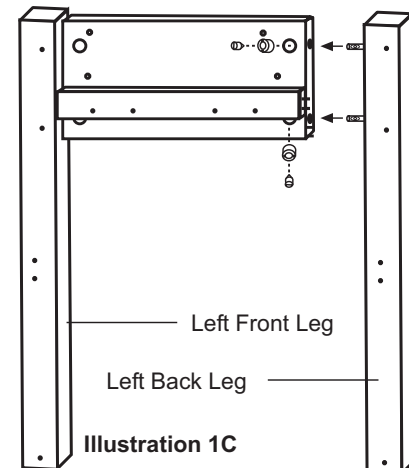
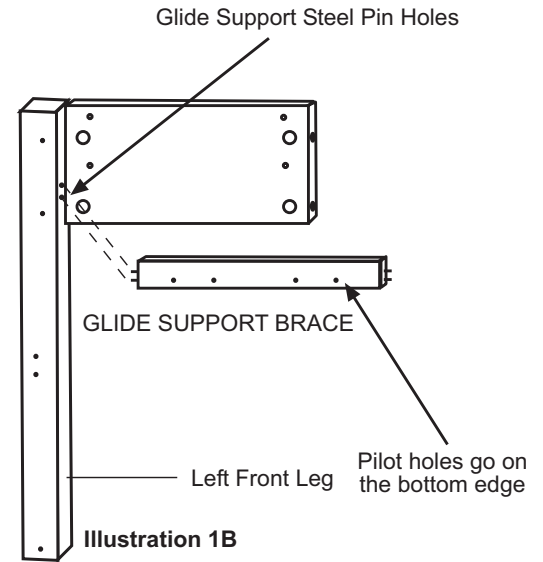
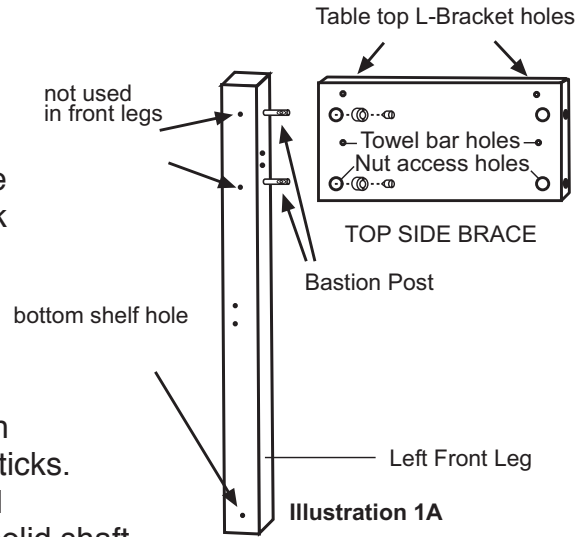

## STEP 2

### ATTACH DRAWER GLIDES TO GLIDE SUPPORT STICKS

A. Take the Drawer Glides, extend them to their fullest. See illustration 4. The Glide has 3 parts. Remove the furthest extended part (1) (smallest) by pushing the black plastic lever down – then pull part out, separating it. This part will attach to the Drawer Side later. Attach the largest parts (2&3) to the Glide Support Stick using holes as illustrated. Attach with 7/16 #6 pan head screws. About 1 1/4" of this glide will overlap the Front Leg. See illustration 2B.

B. Repeat with the other side.

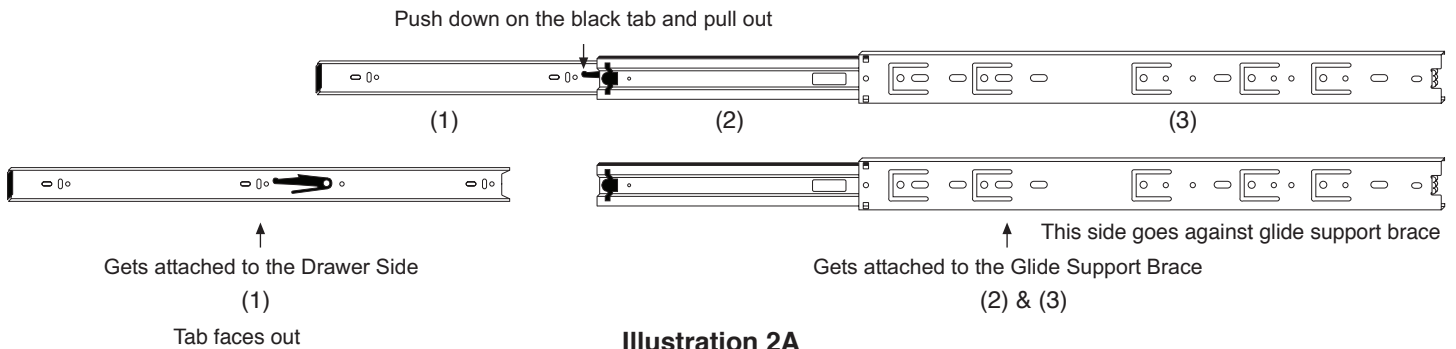

This shows back side of Glide. Part (1) is separated from Parts (2) & (3).  
This side of Part (3) goes against the Glide Support Brace.

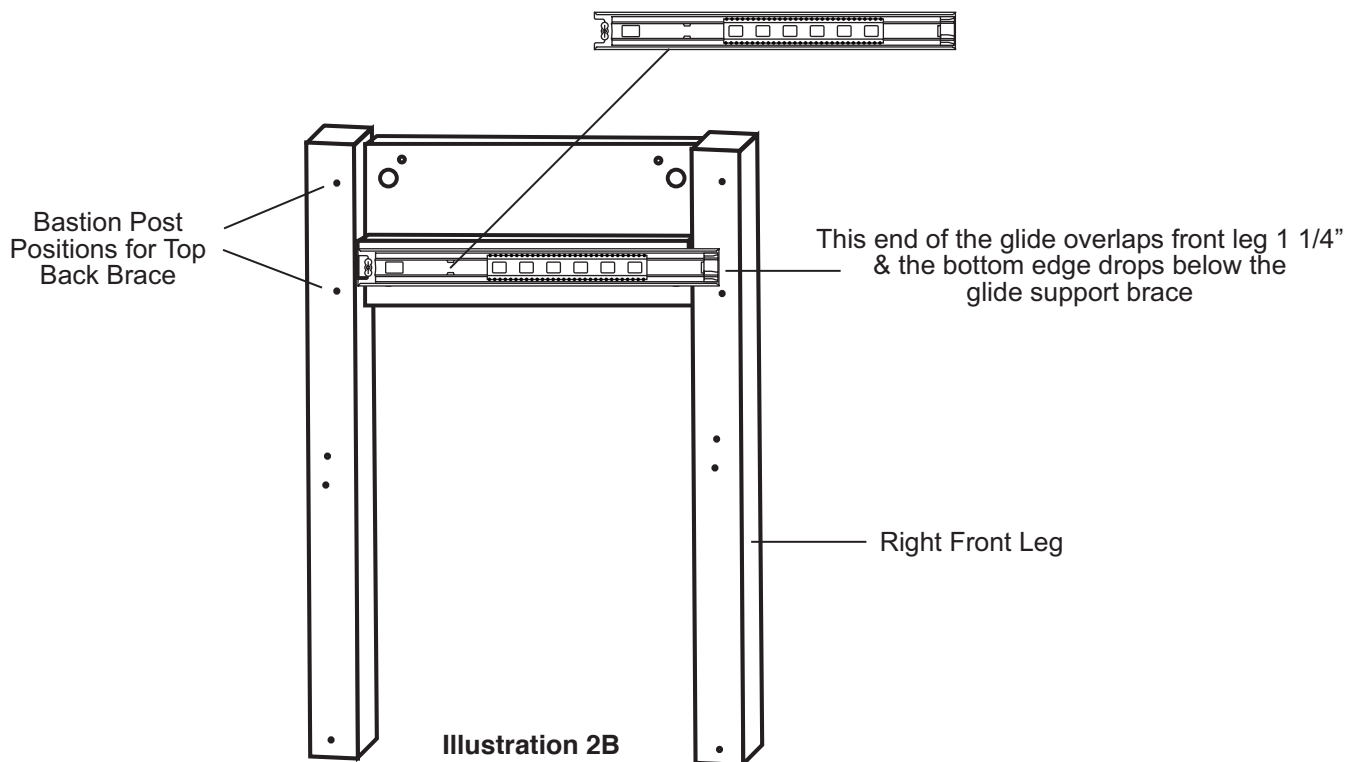

### PREPARE SIDE ASSEMBLIES FOR BACK BRACES

The top back brace utilizes the bastion system for attachment. Place the bastion posts into their positions on the back legs only of both side assemblies.

### STEP 3 ATTACH THE BACK BRACE AND BOTTOM SHELF

A. The Top Back Brace attaches 1 1/4" down on the legs, allowing clearance for the hinges and drop leaf supports. Attach the back brace with bastions to the right and left side assembly. Before tightening the bastions, attach the back wine rack brace, making sure the off-center pipe holes are toward the top of the unit. (See illustration 3B) Use two steel pins for each side. After the back wine rack brace is in position, tighten the top back brace's bastions. See illustration 3A.

B. Insert the metal wine rack pipes into the back wine rack brace. Attach the front wine rack brace to the left leg, off-center pipe holes at the top, and insert the metal wine rack pipes into position, working left to right, finally attaching the front wine rack brace to the right leg. See illustration 3C.

C. While holding the wine rack in position, attach the bottom shelf to the inside of all four legs using the 1 1/4" #8 screws. See illustration 3D.

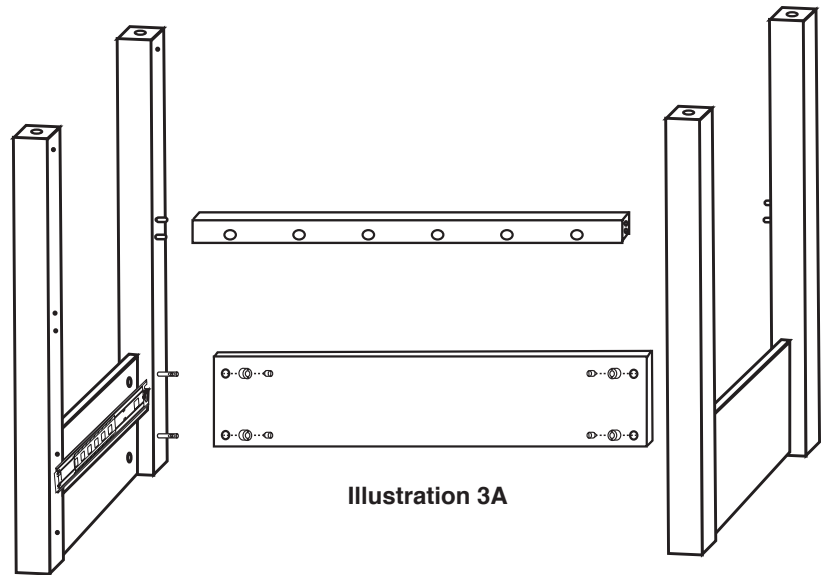

Illustration 3A

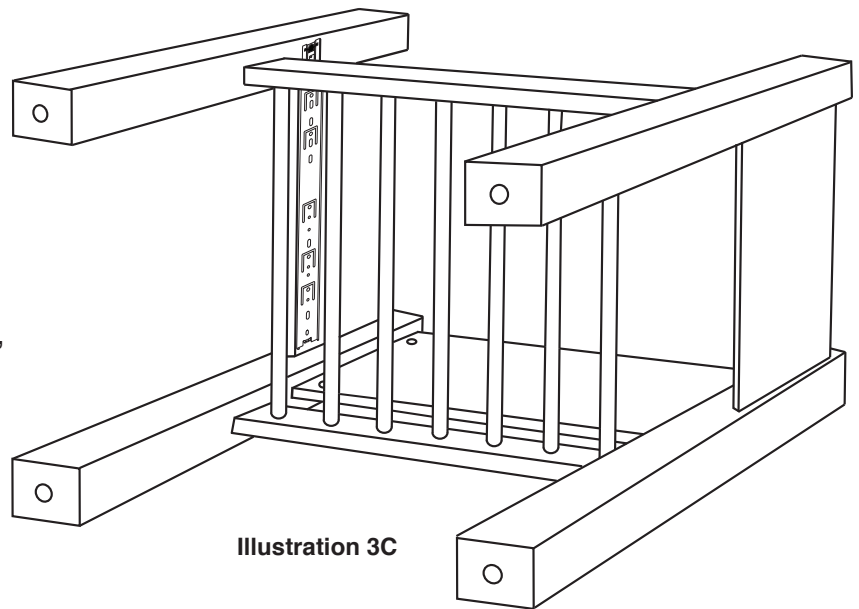

Illustration 3C

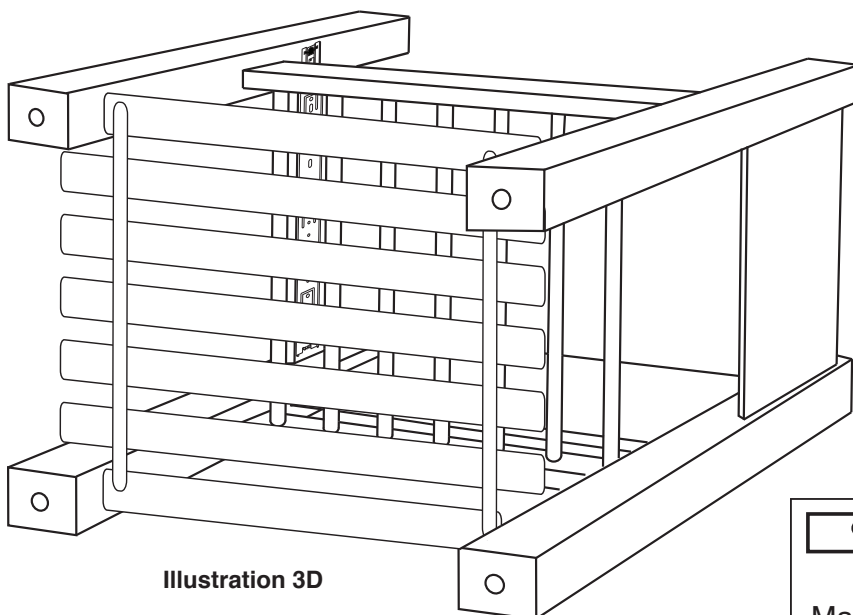
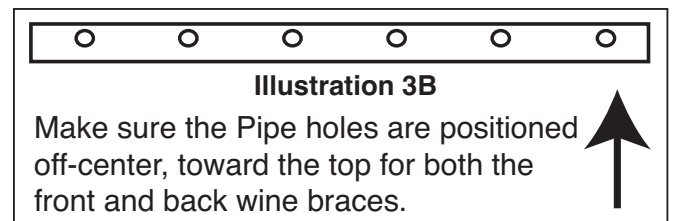

Illustration 3D





## STEP 4 TABLE TOP PREPARATION

A. Invert table top on smooth, flat surface. Attach the 4 L-Brackets with 5/8" #6 screws, using the round hole as shown in Illustration 4B.

B. Attach the 3 hinges with 5/8" #8 screws. Attach drop leaf supports with 5/8" #8 screws as shown in illus. 4A.

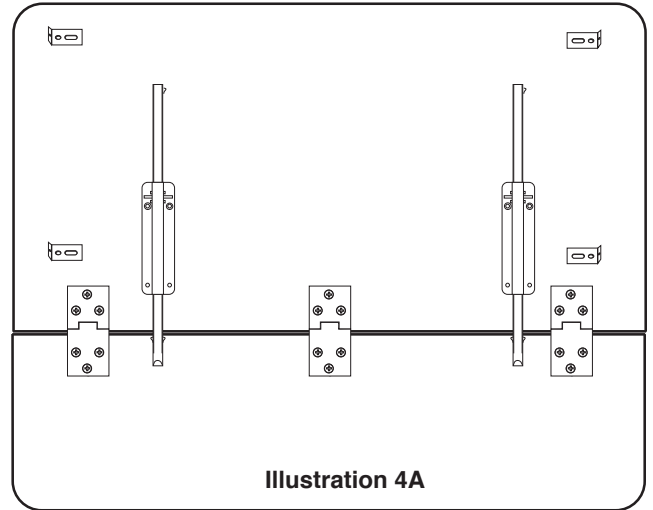
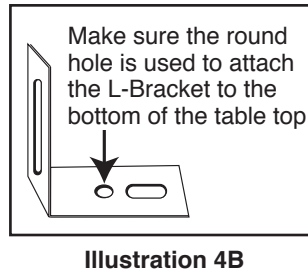
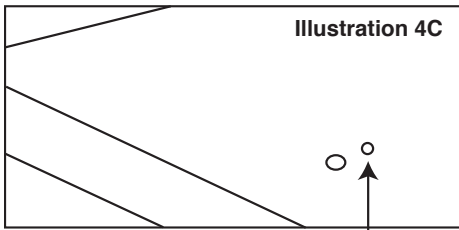

You must use the smaller hole, furthest from the edge for L-bracket attachment, as shown in illustration 4C.

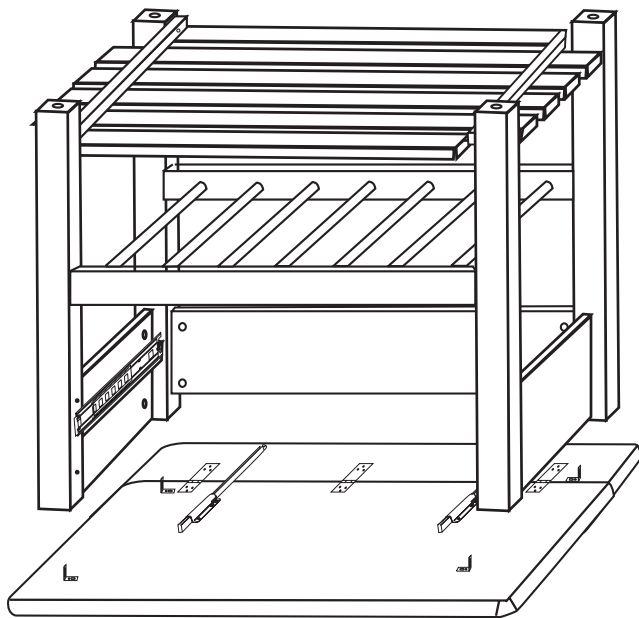

## STEP 5 ATTACH TABLE TOP

A. With the top still inverted, invert the leg assembly onto the top as shown. Secure top to leg assembly with 5/8" #6 screws through L-brackets.

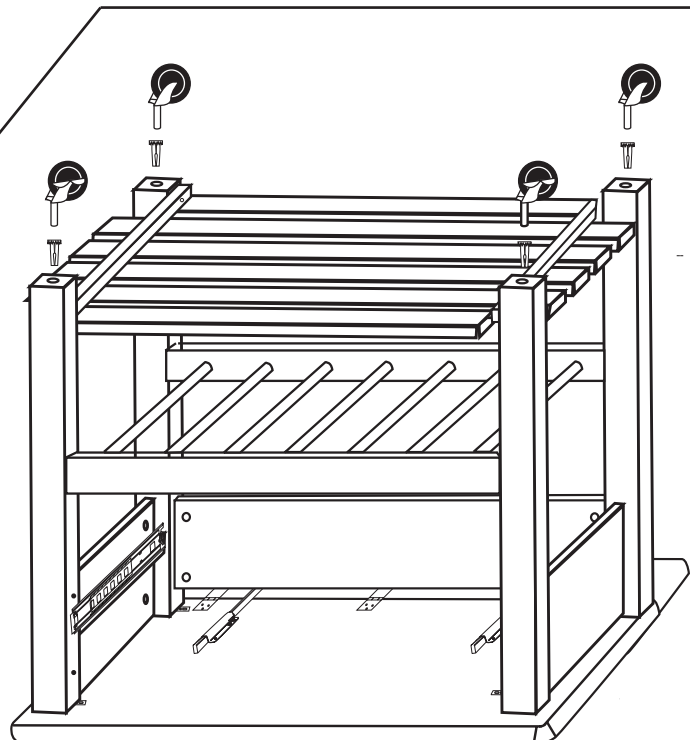

## STEP 6 ATTACH CASTERS

A. With unit still inverted, tap Caster Sockets into holes in leg ends until seated then tap in the Casters.



# STEP 7

## ATTACH TOWEL BARS

**Note: Unit should still be inverted**

See Illustrations. Screw brass towel bar posts into the top side braces and the drawer front using 1 1/4" #8 screws. Attach pipe holder by sliding supports over posts and secure with tiny set screws using allen wrench provided. Slide towel bar through holes in supports and secure in place with set screws. Bar should be equidistant on either side of the supports. Tap end caps into place. See Illustration 7C.

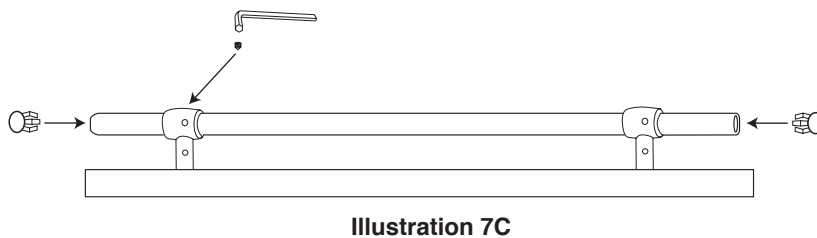
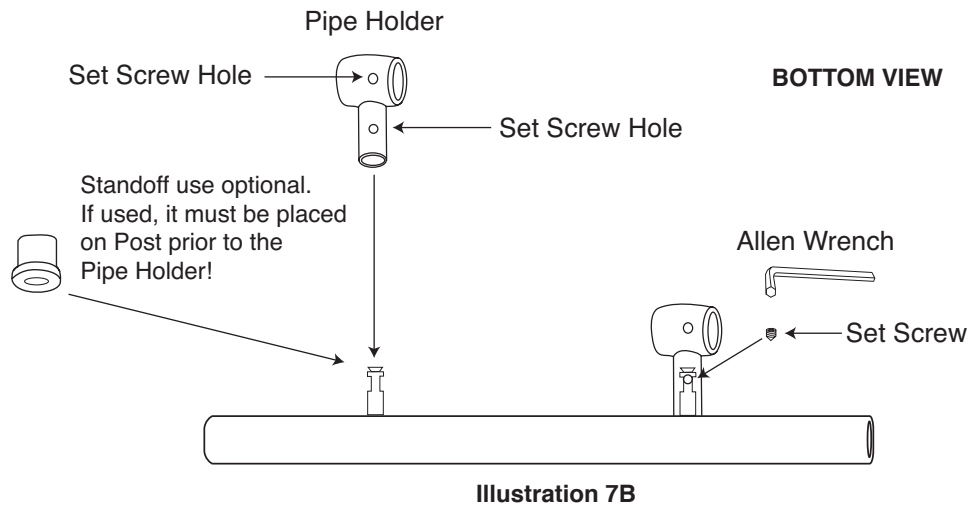
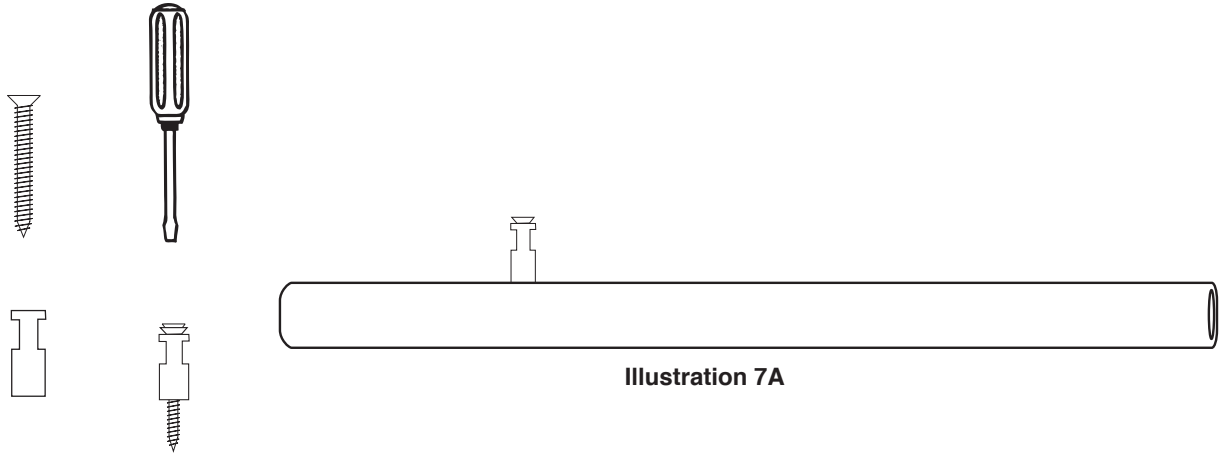

## STEP 8 ASSEMBLE DRAWER

A. Attach the drawer back to the drawer sides with 1 1/4" #8 screws. Slide in drawer bottom, best side up. Attach front using the Bastion System. Holes in the posts will be parallel to the long edge of the drawer front. See illustration.

B. Attach the drawer glide to the drawer sides with 7/16" Pan Head #6 screws in the places indicated in the illustration. Black plastic lever will face outward. Glide will be up against the back of the drawer front.

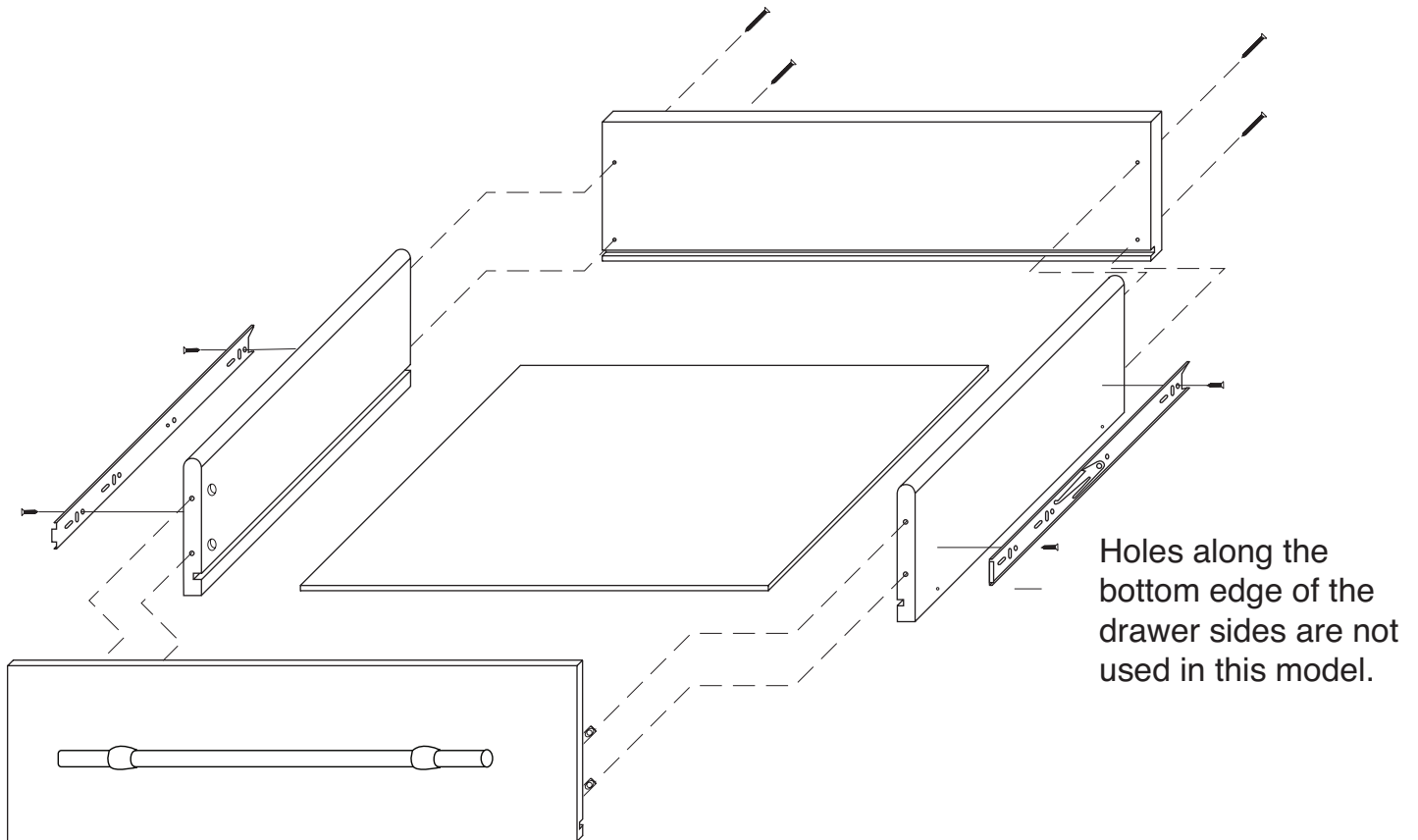

---

## STEP 9 FINAL STEPS

A. Upright unit. Slide drawer into bas. Glides will automatically lock into place.



For continued beauty and long life of your Catskill Craftsmen cart, we recommend Catskill Craftsmen's Butcher Block Oil.

Our Butcher Block Oil is available directly from Catskill Craftsmen's factory. For one eight ounce (8 fl. oz.) bottle, which is sufficient for two applications, simply send \$7.95 along with the completed coupon to the address below. Visit us online at [www.catskillcraftsmen.com](http://www.catskillcraftsmen.com) to browse our assortment of butcher block care products. Visa and Mastercard are accepted online .



Catskill Craftsmen, Inc.  
15 West End Ave.  
Stamford, NY 12167-1296



### BUTCHER BLOCK OIL COUPON

Please send me \_\_\_\_\_ # of bottle(s) of the Catskill Craftsmen Butcher Block Oil at \$7.95 per bottle. My check or money order is enclosed for a total of \$\_\_\_\_\_.

Item code: 2008

Name \_\_\_\_\_

Address \_\_\_\_\_

City \_\_\_\_\_

State \_\_\_\_\_ Zip \_\_\_\_\_

Please make checks payable to Catskill Craftsmen Inc. 15 West End Ave., Stamford, NY 12167-1296