

CATSKILL

C R A F T S M E N , I N C .

Assembly Instructions **Model 51576**

Microwave Cart with Open/Enclosed Storage



GENERAL:

1. You have purchased model 51576.
2. Should you need assistance or need to replace a damaged or missing part simply give us a call M-F at 607-652-7321 from 7:30 am - 4:30 pm EST and we'll send you the prepaid part via UPS usually that same day! You may also email us info@catskillcraftsmen.com.
3. Read the assembly instructions and the enclosed brochure before beginning assembly. Assembly is easy if you read and follow the instructions step by step. See our website for assembly tips and videos.
4. Tools required: Phillips screwdrivers, medium and small; medium flat blade screwdriver and a hammer.
5. Drawer glides are sometimes pre-packed with screws, these are not used.
6. Directions (left/right, front/back) are given as facing the front of an assembled upright unit.

CABINET PARTS 51576

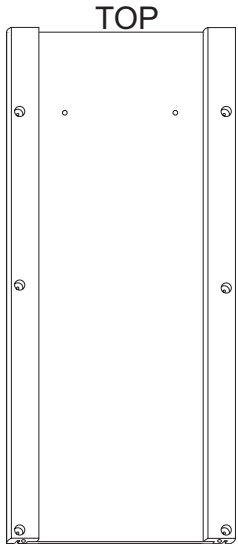

Handle Side Panel (1)
P/N: SP/HDL - 51576

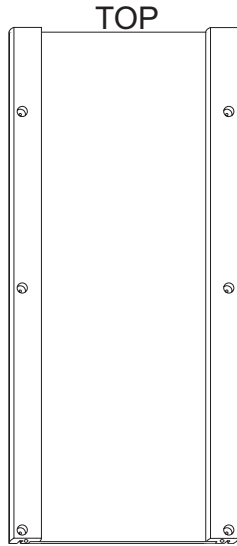

Plain Side Panel (1)
P/N: SP/PL - 51576

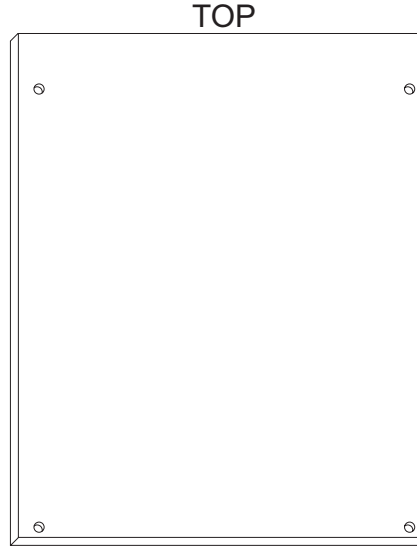

Back Panel (1)
P/N: BP - 51576

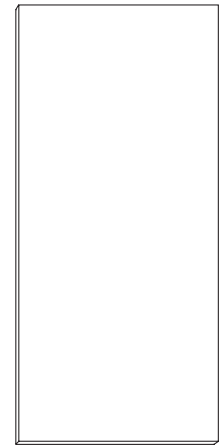

Drawer Bottom (1)
P/N: DBOT - 51576

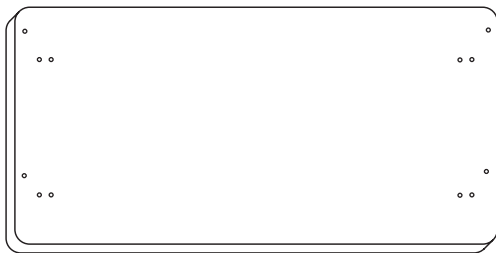

Cabinet Top (1)
P/N: TT - 51576

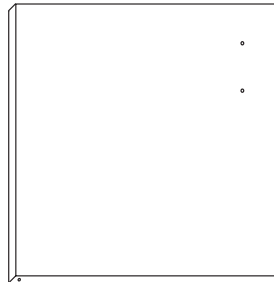

Left Door (1)
P/N: DOR - 51576L

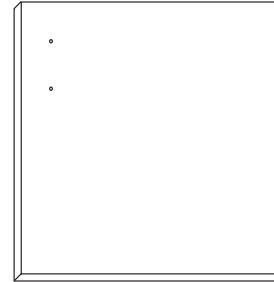

Right Door (1)
P/N: DOR - 51576R



Door Spacer (1)
P/N: DORS - 11 15/16 - 51576

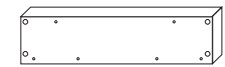

Glide Support Sticks (2)
P/N: GLD SUP - 51576



Drawer Side Left (1)
P/N: DS - 51576L

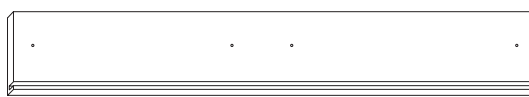

Drawer Front (1)
P/N: DF - 51576



Drawer Back (1)
P/N: DBK - 51576



Drawer Side Right (1)
P/N: DS - 51576R

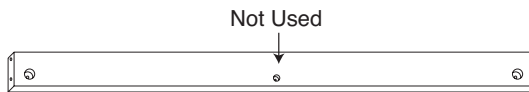

Top/Bottom Braces (2)
P/N: B - 51576 T/B

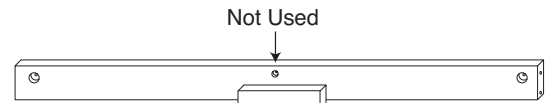

Middle Front Brace (1)
P/N: B - 51576 MF



Rack Top (1)
P/N: RKTP - 51576

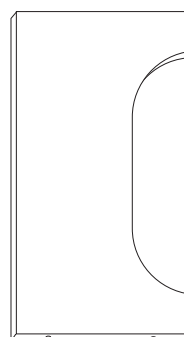

Rack Side Panels (2)
P/N: RKSP - 51576

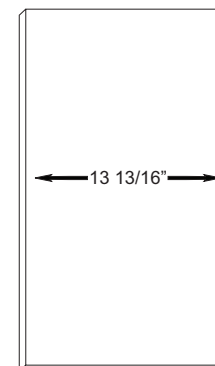

Shelf (2)
P/N: BS - 51576

CABINET HARDWARE 51576



1 3/4" Phillips Flat Head Bolt (10)

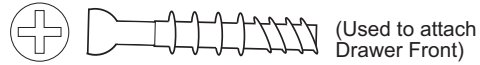

Cam Posts (2)

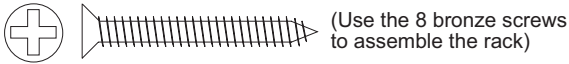

1 1/4" Phillips Flat Head #8 Screw (20)

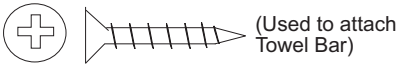

1" Phillips Flat Head #8 Screw (2)



7/8" Truss Head Machine Screw (6)

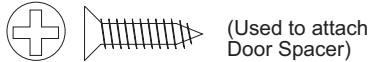

5/8" Phillips Flat Head #8 Screw (2)

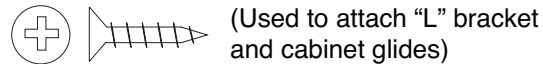

5/8" Phillips Flat Head #7 Screw (12)

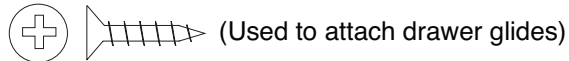

5/8" Phillips Flat Head #5 Screw (4)



1 1/2" Long 3/16" DIA. Steel Pin (4)



1" Long 3/16" DIA. Steel Pin (8)



3/4" Long 3/16" DIA. Steel Pin (6)

MAGNET PACK



Magnet Plate (1)

Magnet (1)

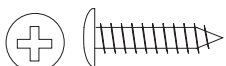

5/8" Pan Head Screw (2)

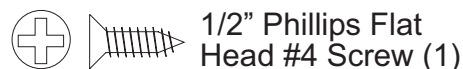

1/2" Phillips Flat Head #4 Screw (1)

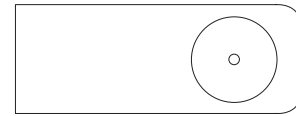

Towel Bar Post (2)

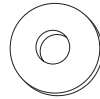

3/16" Flat Washer (4)

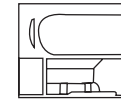

Cam (2)



10-24 Hex Nut (10)



5/8" Wooden Disk (12)

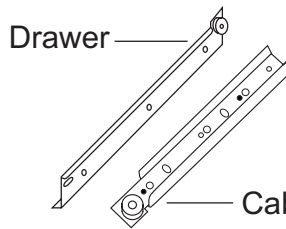

14" Drawer Glide (1 Set)

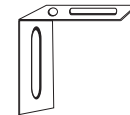

"L" Bracket (4)

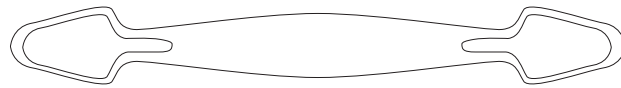

Nickel Handle (3)

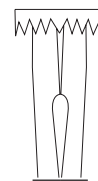

Caster Socket (4)

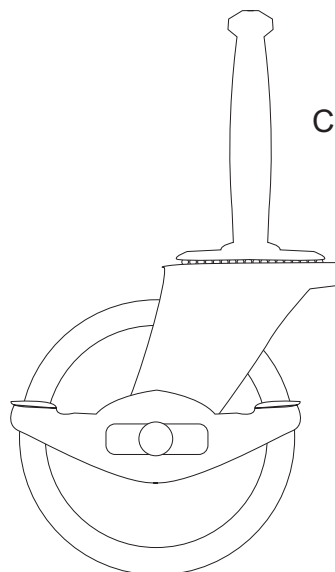

Locking Wheel Caster (2)

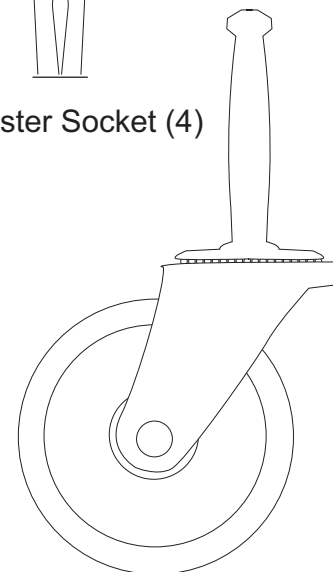

Non-Locking Wheel Caster (2)

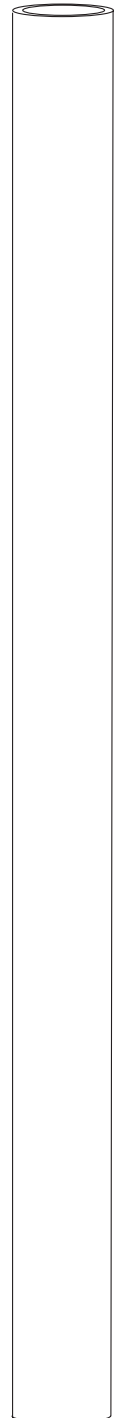

Polished Nickel Towel Bar (1)

STEP 1

1. Attach the Rack Top to the top ends of the Side Panels (universal: same left/right & top/bottom) using 1 1/4" #8 wood screws. **MAKE SURE YOU HAVE THE RACK TOP!** The only difference between the Rack Top and the Cabinet Top is that the Cabinet Top has 4 small pilot holes on the bottom side plus the 4 through holes; whereas, the Rack Top only has the 4 through holes.

NOTE: On the Rack Top the countersunk (reamed out) through holes face up and the countersunk holes/pilot holes on the Cabinet Top face down. The countersunk holes allow the screw heads to be flush with the wood surface when tightened down.

2. Turn this assembly upside down so that the Rack Top is on a smooth flat surface. Attach the Cabinet Top with four 1 1/4" #8 wood screws. With the unit upside down at this point, the 4 pilot holes should be up. See illustration 1B.

3. Leave this assembly UPSIDE DOWN and go to STEP 2.

NOTE: The cart cabinet will be constructed upside down using the bottom of the Cart Top as the base.

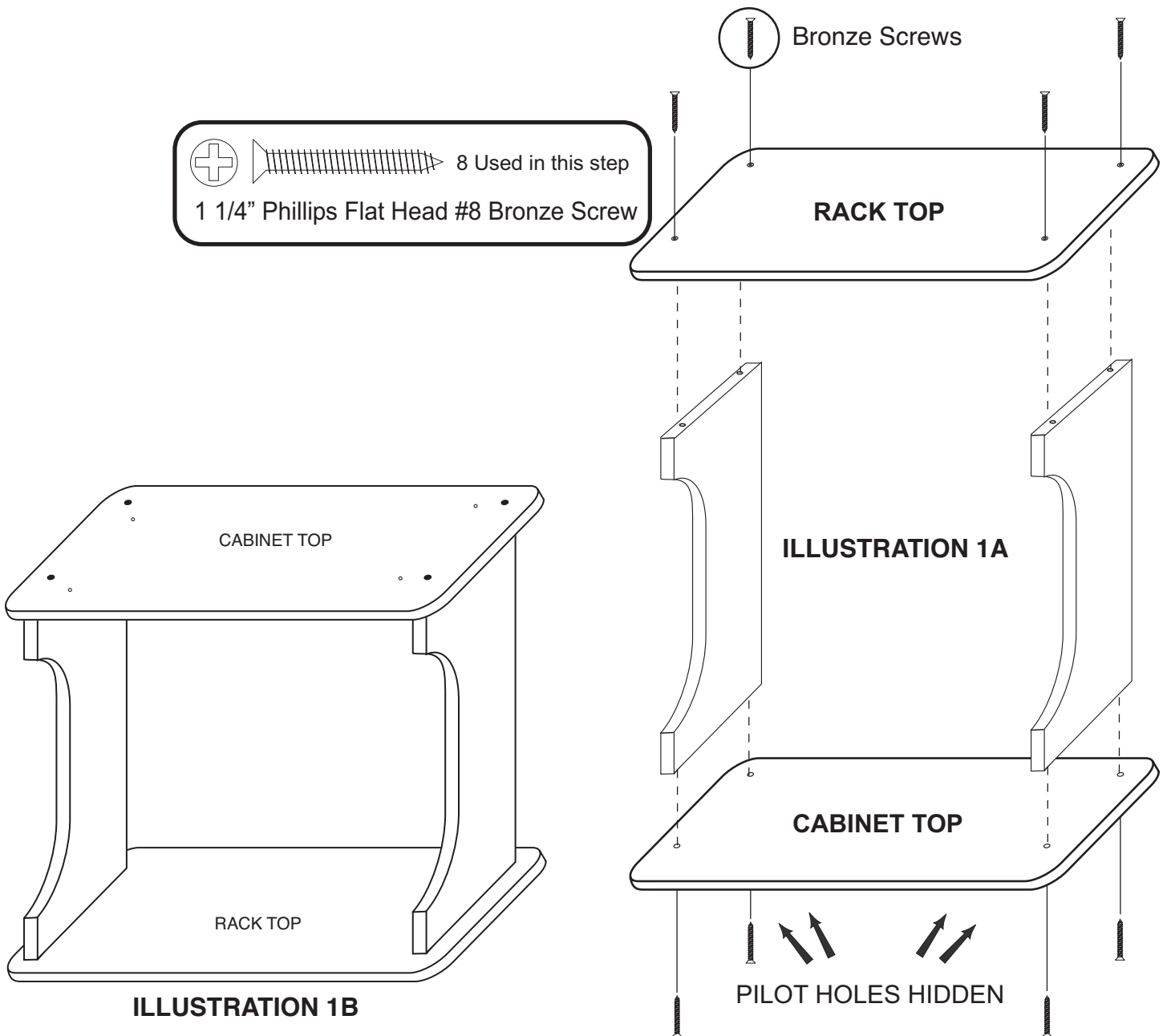

STEP 2

Note: The side panels are interchangeable at this point. Drawer glides will determine left or right sides. Choose at this point if you want the towel bar/handle on the left or right panel. We are using the left side for these instructions. Cover photo shows towel bar/handle on right side.

A. Attach a Glide Support Stick to the top of each Side Panel using 1 1/4" #8 screws. The Sticks should be flush with top of panel.

B. Attach the cabinet glide of the Drawer Glides to the Glide Support Stick using 5/8" #7 flat head screws. Left glide to left Side Panel, right glide to right Side Panel. The glides look almost alike however, the right glide (as you face the cart) has a rolled lip at the top of the glide that keeps the drawer glide wheel in place. Line up the holes in the glides so that the end with the wheel comes flush with the front edge of the Glide Support Stick.

C. Attach the "L" brackets to the top of the glide supports using 5/8" #7 screws. Use the long slot rather than hole/slot. The hole will be used to attach the table top. The "L" brackets should be flush with the top of the glide support sticks.

Note: Cabinet drawer glides usually have an imprint "CL" or "CR" inside near the wheel.

CR=Right / CL=Left

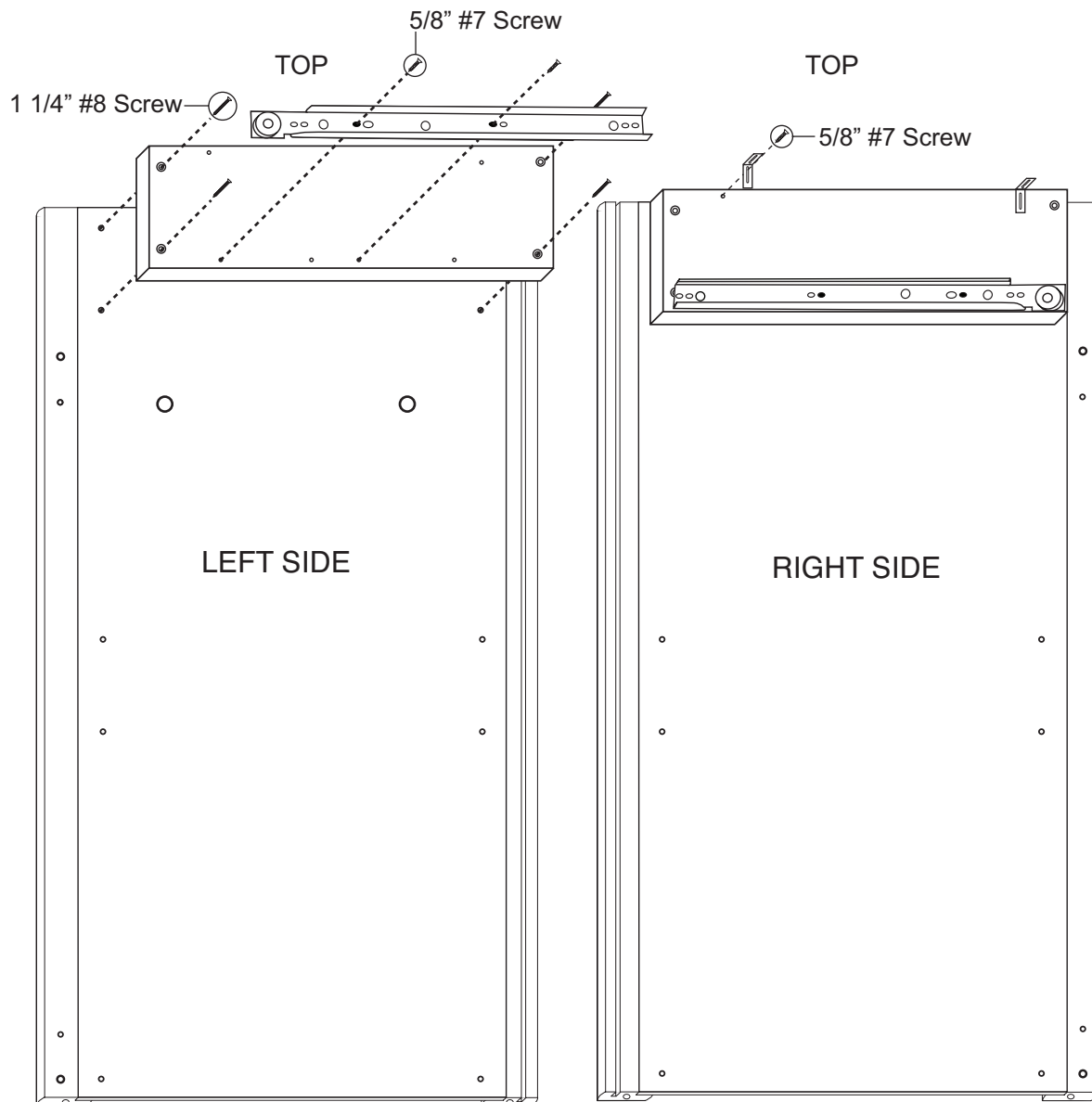

STEP 3

A. Lay Back Panel flat on a smooth surface with holes up.

B. Attach Side Panels with 1 3/4" bolts and hex nuts. After inserting bolts(s) thru the holes in the Side Panels, thru the holes in the long edges of the Back Panel, place a hex nut on the tip of your finger, align nut with bolt and tighten.

C. Look ahead to step 5 which shows side panels attached to back panel.

NOTE: Make sure you position the side panels according to Drawer Glides (left or right).

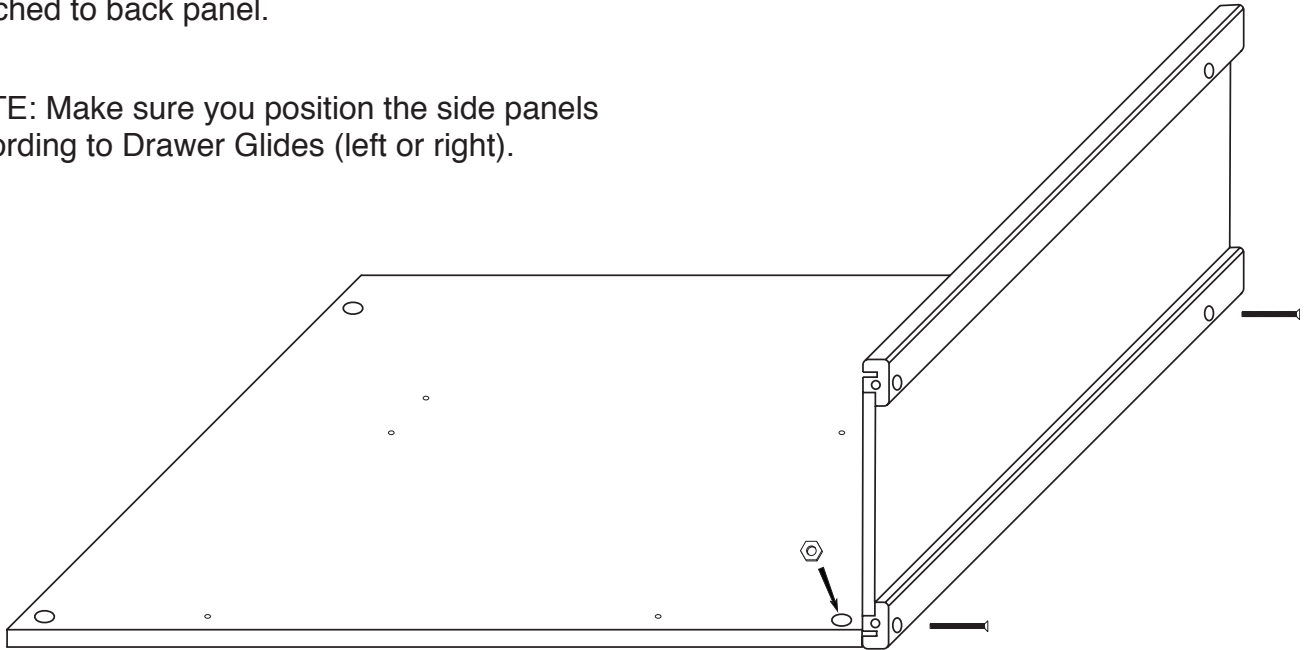
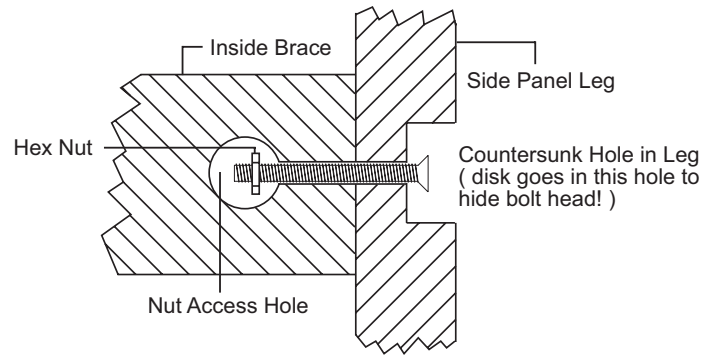

STEP 4

STEPS 5 - 14 WILL BE ACCOMPLISHED WITH THE UNIT TOP UPSIDE DOWN (INVERTED), BUILDING UPWARD TOWARD THE BOTTOM/ CASTER END! BE CAREFUL AS PART DESCRIPTIONS ARE BASED ON AN UPRIGHT, COMPLETED UNIT!

Mark a Large (X) mark over each of the 4 pilot holes in the bottom. Make marks about 1 1/2" long. These marks will help you align the cabinet with the pilot holes in step 5.

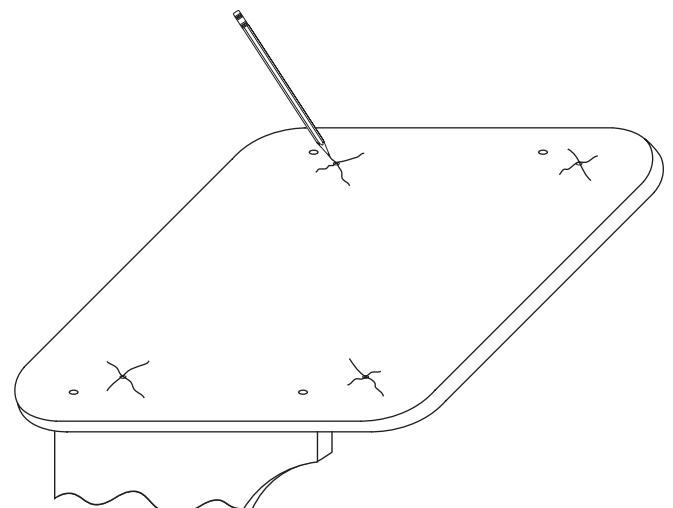

STEP 5

- A. Turn the side/back assembly (from step 1) upside down (invert) on top of the inverted table top.
- B. Using the (X) marks from step 4 as a guide, insert the tips of the 5/8" #7 screws through the "L" bracket and into the pilot holes in the unit top and finger tighten. When all 4 screws are properly aligned, tighten down.
- C. Tap two 1" pins into each side panel. These pins will hold the bottom shelf.



(Used to attach
"L" brackets)

5/8" Phillips Flat Head #7 Screw



4 Used in this step

1" Long 3/16" DIA. Steel Pin

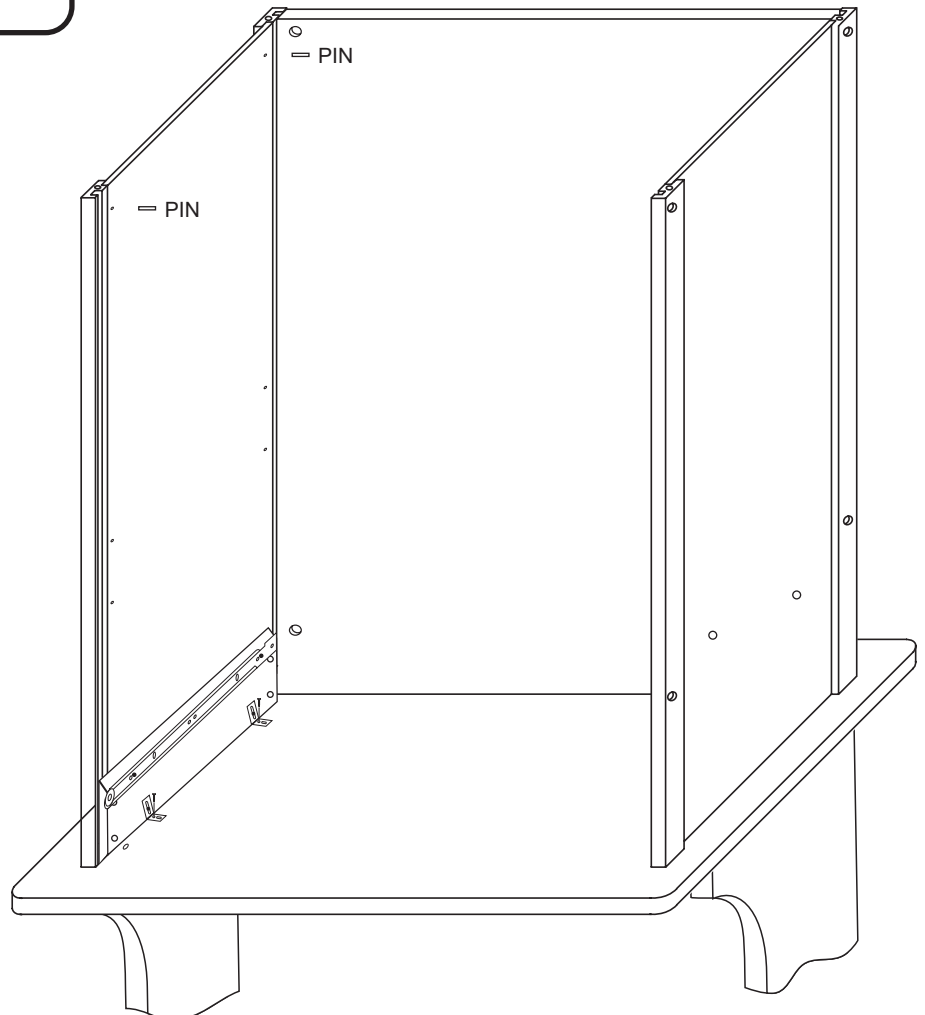

STEP 6

A. Attach the drawer back to the drawer sides with four 1 1/4" #8 screws. Make sure parts are aligned as in illustration 6A.

B. Insert drawer bottom into the slots in the drawer sides, best side to inside of drawer. Slide down until seated in the slot in the drawer back. See illustration 6B.

C. Screw the cam posts into the two outside holes on the inside face of the drawer front until seated. Only 3/8" of the post goes into the wood, leaving the 4 larger guide rings/head exposed. See illustration 6C. Visit us at www.catskillcraftsmen.com to view our cam video.

D. Insert the posts into holes in the drawer sides until seated against the front end of the drawer sides. Insert cams so that slot in the cam fits over the post and turn with Phillips screwdriver until seated. Don't over-torque! See illustration 6D. See our video online at www.catskillcraftsmen.com

E. Attach drawer handle with two 7/8" Truss Head screws each. (no illustration).

F. Attach drawer glides to drawer sides using 5/8" #5 screws. See illustration 6E

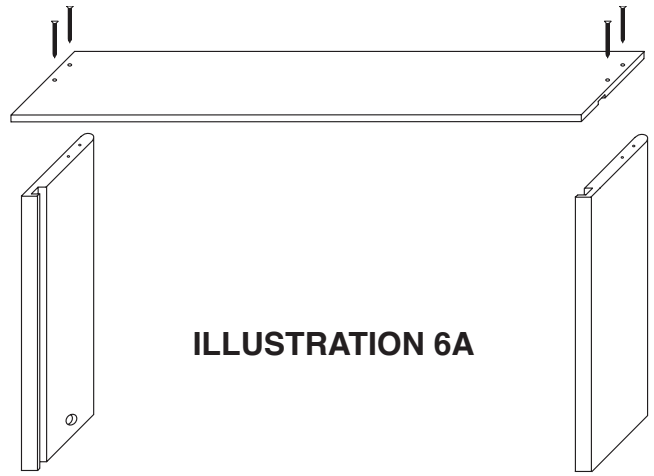

ILLUSTRATION 6A

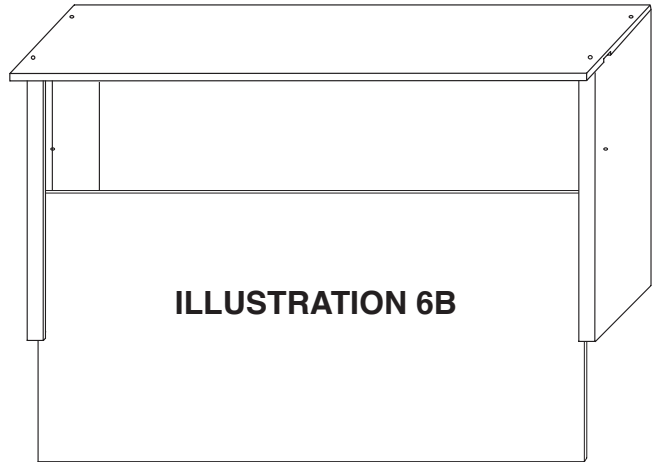

ILLUSTRATION 6B

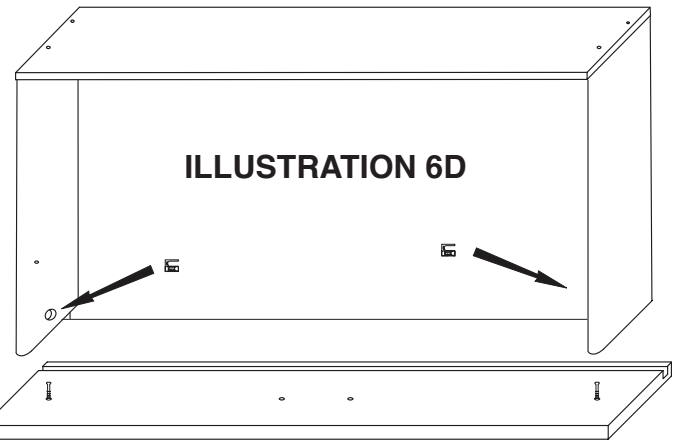

ILLUSTRATION 6D

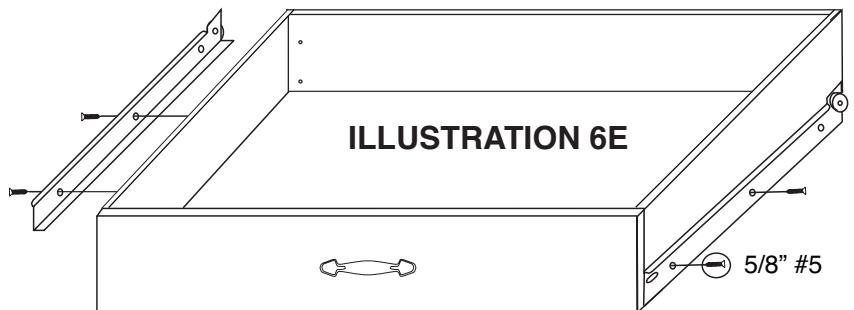
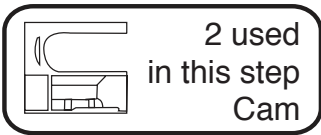
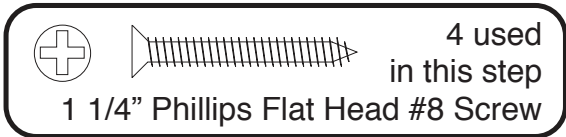
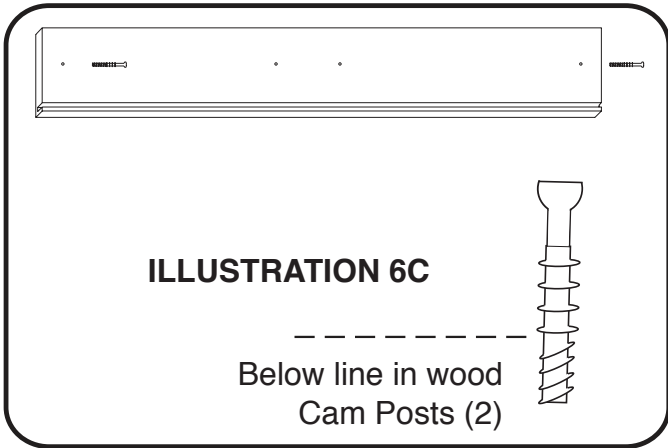
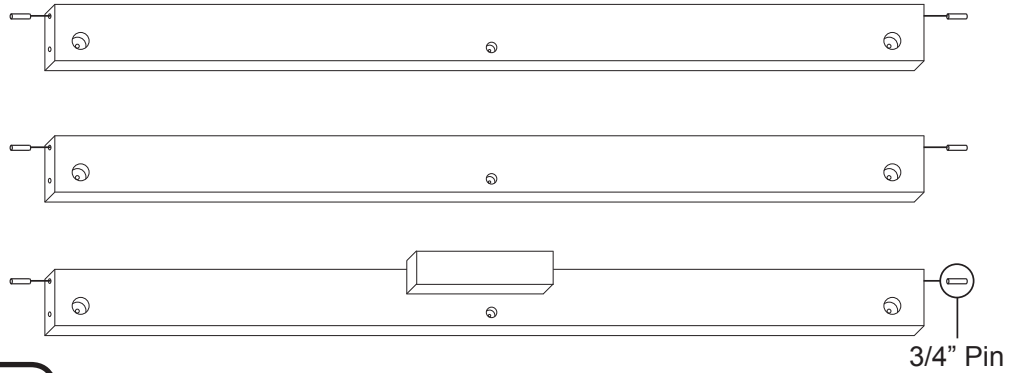

ILLUSTRATION 6E



STEP 7

Take the 2 front braces and tap/insert one 3/4" steel pin into each end of both braces until seated. About 3/8" will stick out when seated. Ok if loose.



 6 used in this step
3/4" Long 3/16" DIA. Steel Pin

Install 3/4" pins in brace ends

STEP 8

A. Take the top front brace, insert the pins in the brace ends into the slots on the inside of the front legs and slide down until the brace aligns with the bolt holes as illustrated. The pin holes for the door pins will be up. Secure with 1 3/4" bolts/nuts. Repeat with the middle front brace. Magnet block and pin holes will be facing up.

 4 used in this step
10-24 Hex Nut

 4 used in this step
1 3/4" Phillips Flat Head Bolt

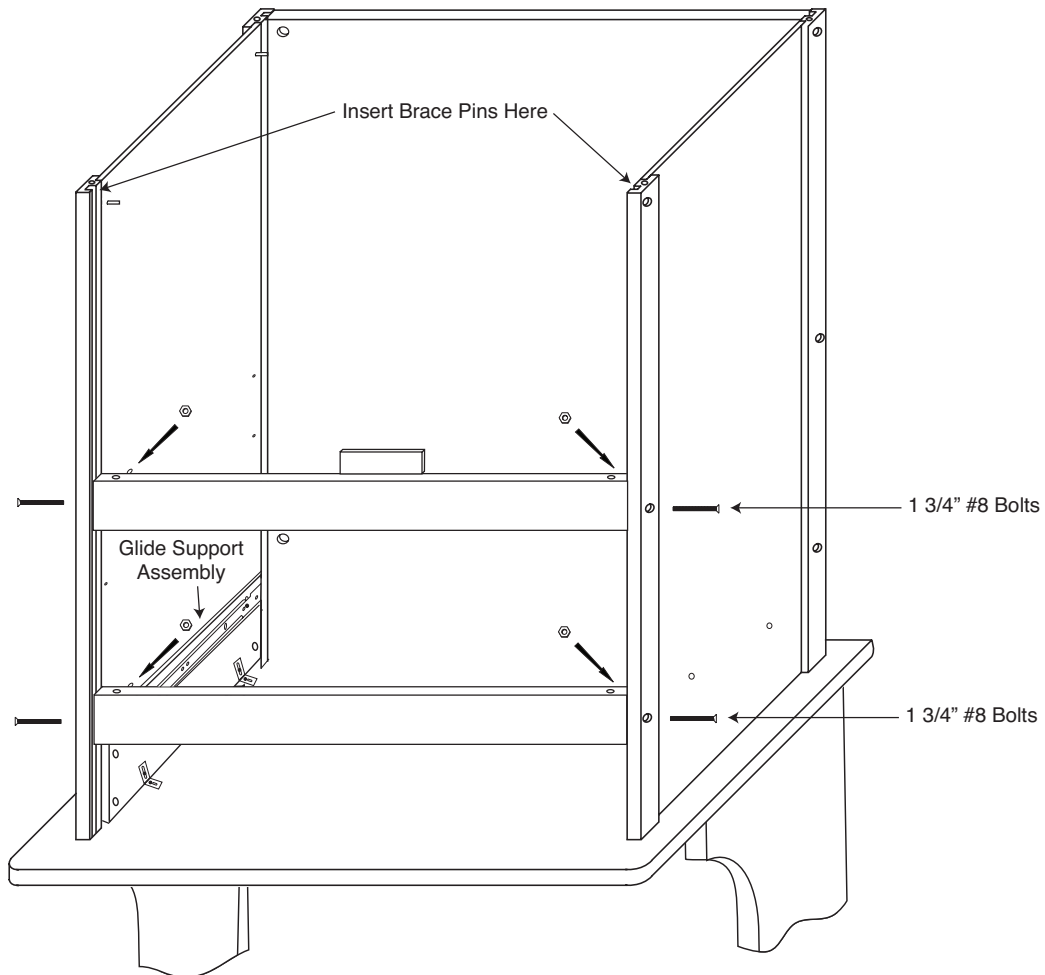

STEP 9

Attach towel bar to side panel with 1" #8 screws/washer from inside one panel.

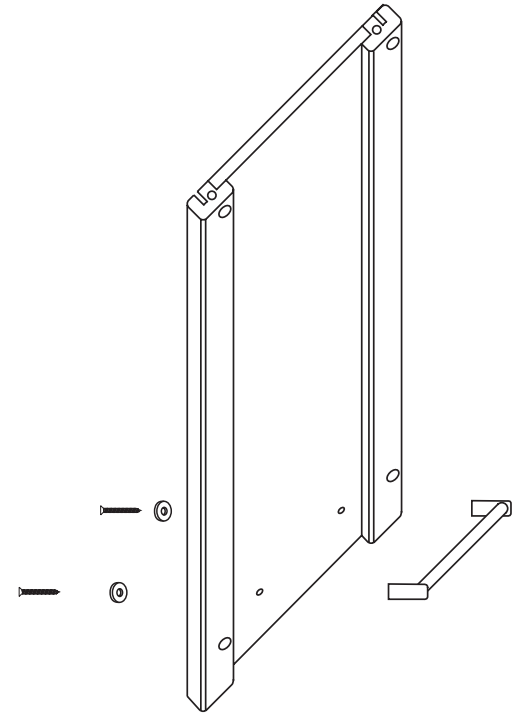
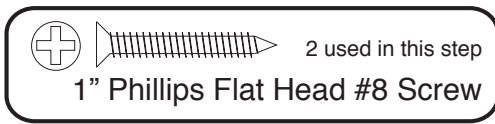

STEP 10

- Tap/insert ONE 1 1/2" pin into each end of both doors. DON'T OVERDRIVE PINS! Pins should stick up about 1/2" when seated.
- Attach the doorspacer to the left door with 5/8" #8 screws. The spacer has a space at the top to allow magnet clearance and is almost flush with the bottom of the door. Countersunk holes out.
- Attach the magnet plate (may be stuck to magnet!) with the 1/2" #4 screw to the top of the right door. Bumps go toward the wood.
- Attach door handles with 7/8" truss head machine screws.

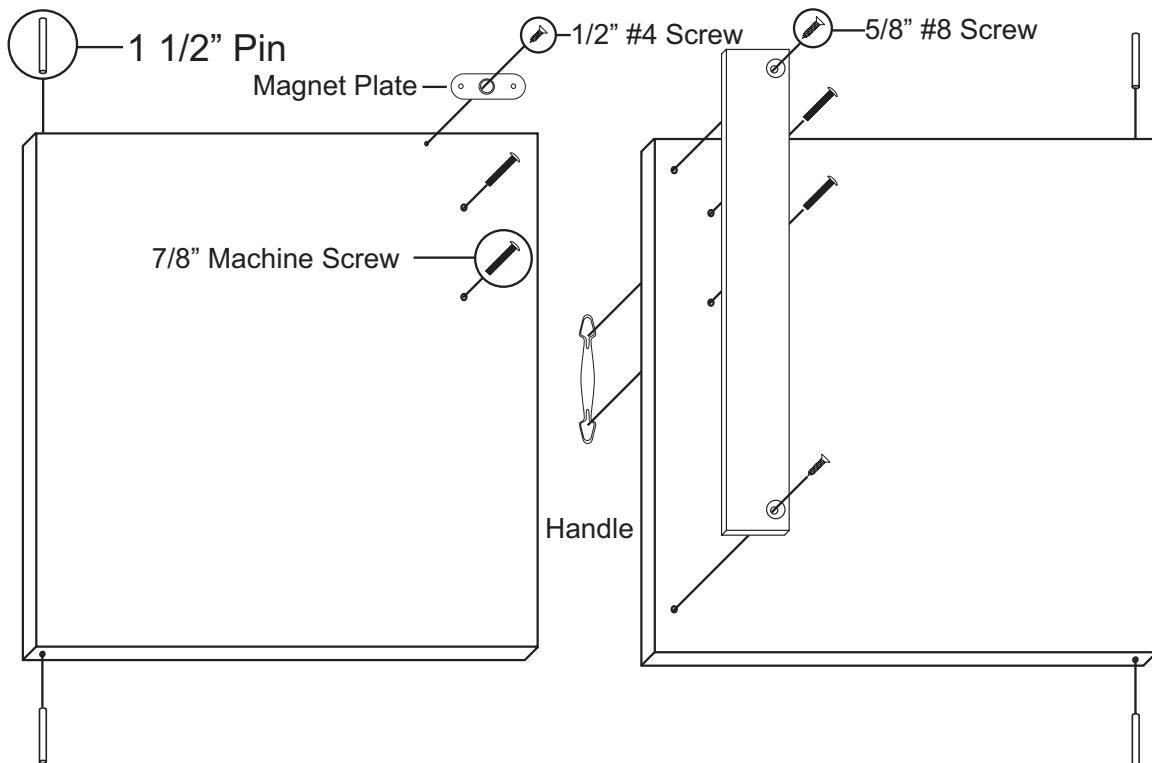

STEP 11

A. Install doors by inserting pins in the door tops into the holes in the long edge of the middle front brace.

B. Place one washer on each of the door pins in the door bottoms.

C. Take the bottom front brace, align pins in the door bottoms with holes along top long edge of brace (are washers on pins?) and secure brace with 1 3/4" bolt/hex nuts as before.

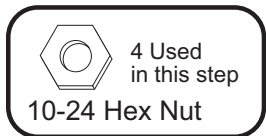
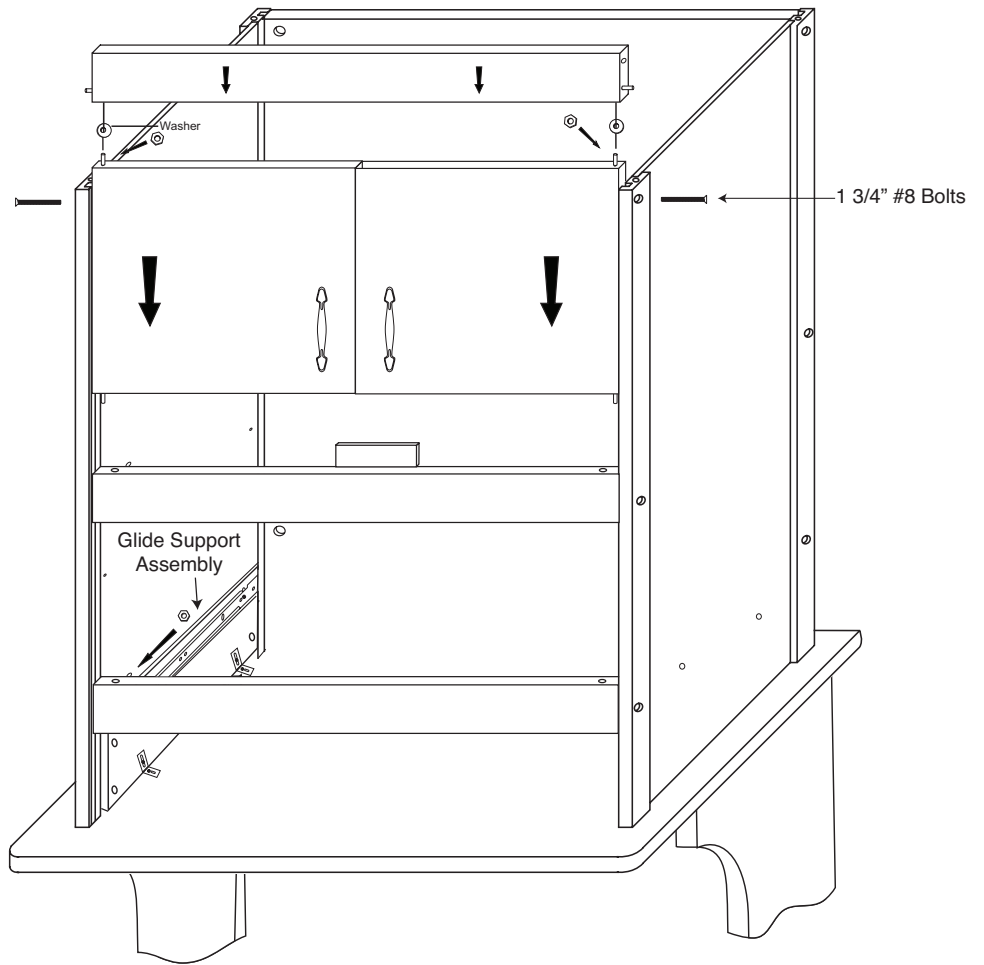

STEP 12

A. Stick magnet to magnet plate on right door.

B. With left door open, close the right door. The magnet should be positioned over the wooden block on the bottom of the top front brace. Hold the magnet in place with your thumb, and open the right door. The magnet will be in the correct position on the block.

C. Secure magnet with the two round head screws in the magnet packet. Center screws in the slots in the magnet. This will allow adjustment later, if needed.

NOTE: No pilot holes in block as softwood!

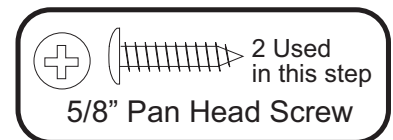
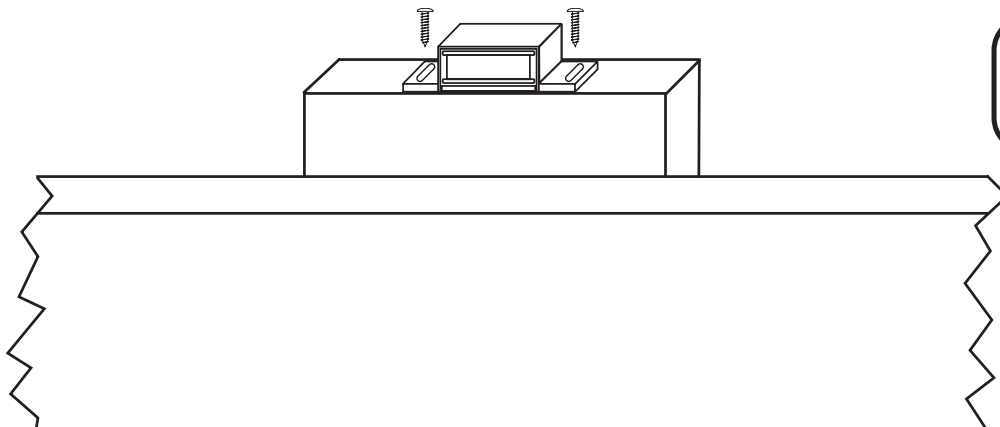

STEP 13

A. Insert and tap caster sockets with hammer until the teeth grab the wood. **DON'T POUND SOCKET FLAT OR CASTER SHAFT WILL NOT ENTER.**

B. Insert casters and seat by pushing straight downward with heel or your hand, or tap into place with a hammer. Don't be afraid to give them a good downward whack on the solid metal part of the caster!

C. Locking wheels usually go on front.

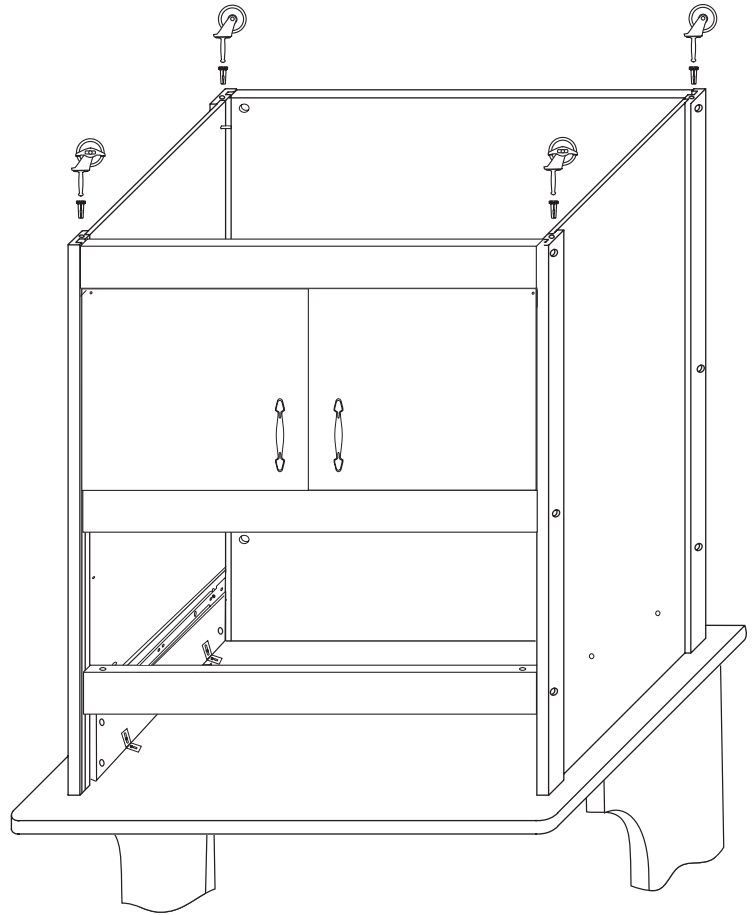

STEP 14

A. Upright unit. Tap 1" pins into holes in the side panels (4 per side) for shelves.

B. Take bottom shelf and place it on the set of back pins. Close doors and shelf will drop into place.

C. Place top shelf on pins.

D. Insert drawer. If drawer front hits the bottom of the cabinet tap on the top front brace or tap top front brace down. Loosen bolts as necessary. When drawer moves freely, retighten all bolts!

E. Tap wooden disks into sides.

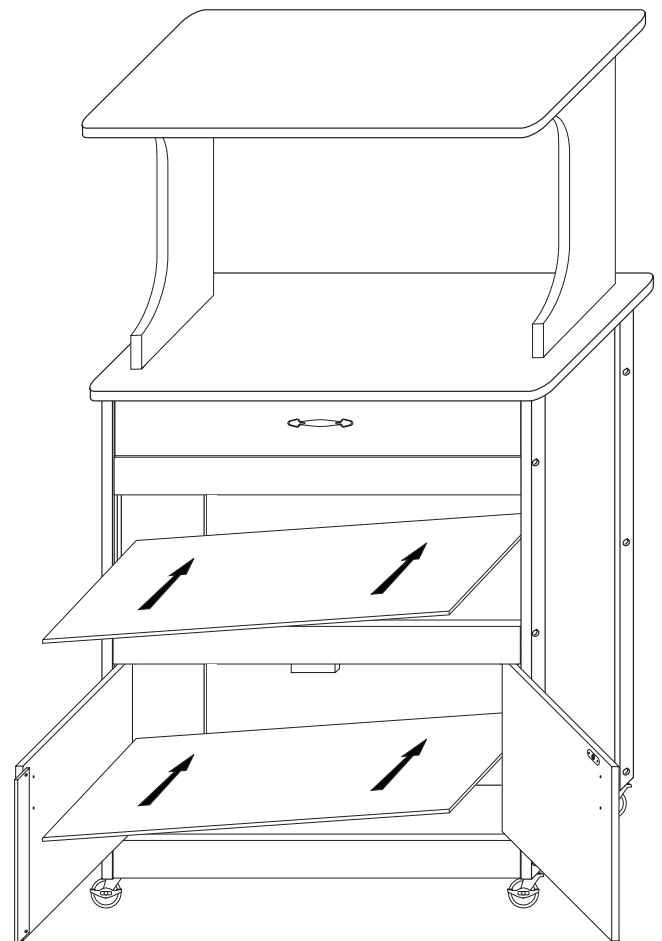



For continued beauty and long life of your Catskill Craftsmen cart, we recommend Catskill Craftsmen's Butcher Block Oil.

Our Butcher Block Oil is available directly from Catskill Craftsmen's factory. For one eight ounce (8 fl. oz.) bottle, which is sufficient for two applications, simply send \$6.95 along with the completed coupon to the address below. Visit us online at www.catskillcraftsmen.com to browse our assortment of butcher block care products. Visa and Mastercard are accepted online .



Catskill Craftsmen, Inc.
15 West End Ave.
Stamford, NY 12167-1296



BUTCHER BLOCK OIL COUPON

Please send me _____ # of bottle(s) of the Catskill Craftsmen Butcher Block Oil at \$6.95 per bottle. My check or money order is enclosed for a total of \$_____.

Item code: 51576

Name _____

Address _____

City _____

State _____ Zip _____

Please make checks payable to Catskill Craftsmen Inc. 15 West End Ave., Stamford, NY 12167-1296