

CATSKILL

C R A F T S M E N , I N C .

Assembly Instructions Model 61533

*Deluxe Butcher Block Cart
with Flat Panel Doors and Backsplash*



GENERAL:

1. You have purchased model 61533.
2. Should you need assistance or need to replace a damaged or missing part simply give us a call M-F at 607-652-7321 from 7:30 am - 4:30 pm EST and we'll send you the prepaid part via UPS usually that same day! You may also email us info@catskillcraftsmen.com.
3. Read the assembly instructions and the enclosed brochure before beginning assembly. Assembly is easy if you read and follow the instructions step by step. See our website for assembly tips and videos.
4. Tools required: Phillips screwdrivers, medium and small; medium flat blade screwdriver and a hammer.
5. Drawer glides are sometimes pre-packed with screws, these are not used.
6. Directions (left/right, front/back) are given as facing the front of an assembled upright unit.

CABINET PARTS 61533

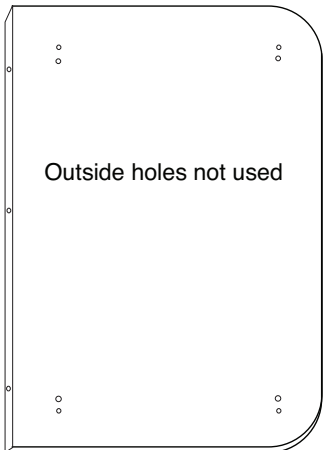
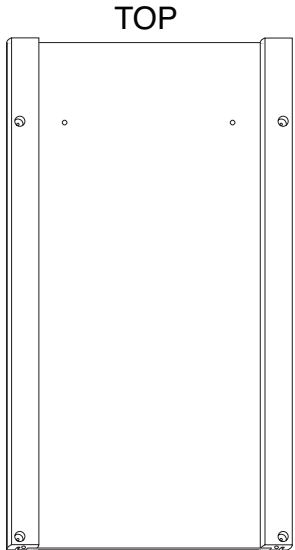
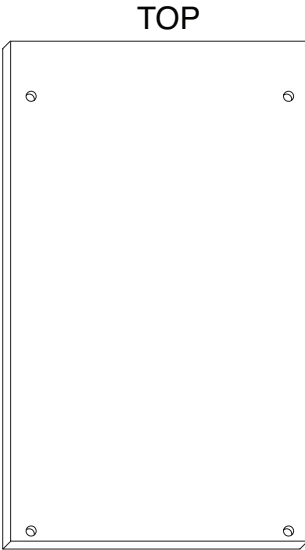

Table Top (1)
P/N: TT-61533



Side Panel (2)
P/N: SP-61533



Back Panel (1)
P/N: BP-61533



Glide Support Sticks (2)
P/N: GLD SUP - 61533

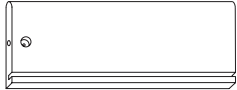

Drawer Side Left (1)
P/N: DS - 61533/L

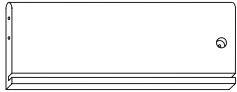

Drawer Side Right (1)
P/N: DS - 61533/R

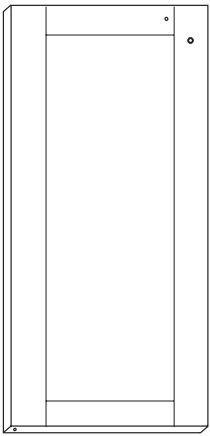

Right Door (1)
P/N: DOR-61533/ RP/R

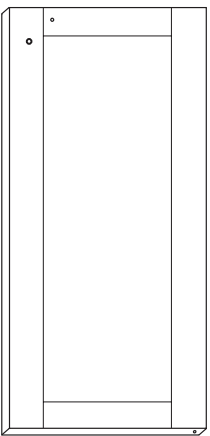

Left Door (1)
P/N: DOR-61533/ RP/L

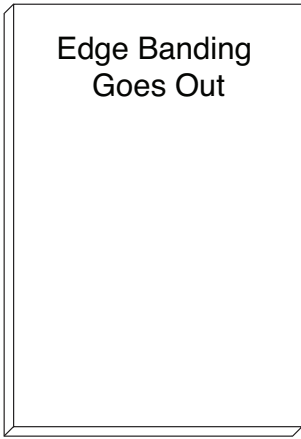

Middle Shelf (1)
P/N: MS - 61533

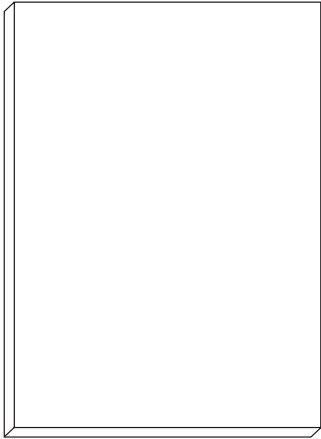

Bottom Shelf (1)
P/N: BS - 61533

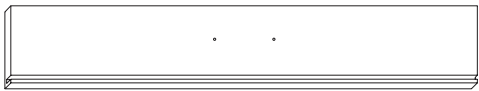

Drawer Front (1)
P/N: DF - 61533

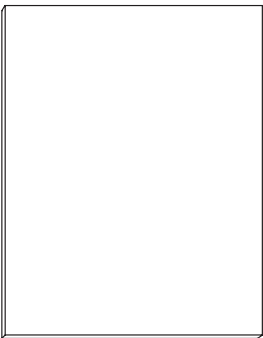

Drawer Bottom (1)
P/N: DB - 61533

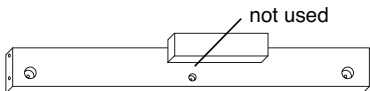

Top Brace (1)
P/N: B-20 1/2 - TF - 61533

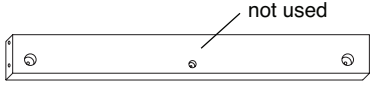

Bottom Brace (1)
P/N: B-20 1/2 - BF - 61533

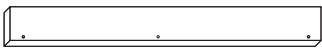

Back Splash (1)
P/N: BSP - 61533

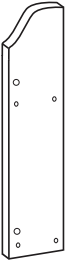

Spice Rack Left Side (1)
P/N: SR - 61533L

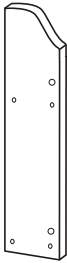

Spice Rack Right Side (1)
P/N: SR - 61533R

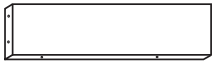

Spice Rack Shelves (2)
P/N: SRS - 61533

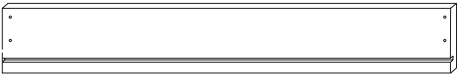

Drawer Back (1)
P/N: DBK - 61533

HARDWARE 61533



1" Phillips Flat Head #8 Screw (4)

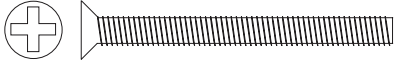

1 3/4" Phillips Flat Head Bolt (8)

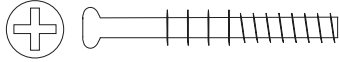

Cam Posts (2) (used on drawer front)



1 1/4" Phillips Flat Head #8 Screw (23)



7/8" Truss Head Machine Screw (4)



1" Truss Head Machine Screw (2)

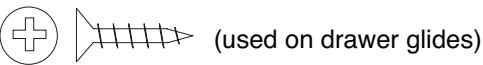

5/8" Phillips Head #5 Screw (4)

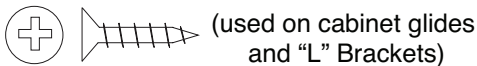

5/8" Phillips Head #7 Screw (12)

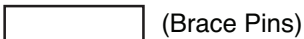

3/4" Long 3/16" DIA. Steel Pin (4)



1" Long 3/16" DIA. Steel Pin (8)



1 1/2" Long 3/16 DIA. Steel Pin (4)

Magnet Packs (2)

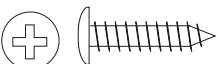

5/8" #6 Pan Head Screw (4)

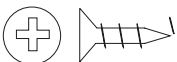

1/2" Phillips Flat Head #4 Screw (2)

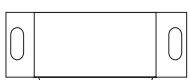

Magnet (2)

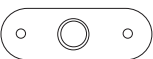

Magnet Plate (2)

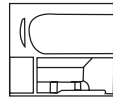

Cam (2)

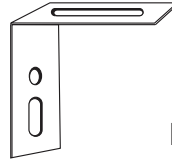

L-Bracket (4)

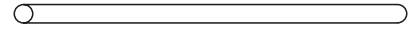

Retainer Rods for Spice Rack (2)

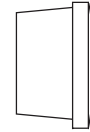
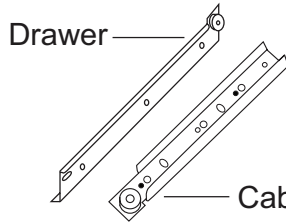

5/8 Wooden Disk (8)



10-24 Hex Nut (8)



Nickel Handle (3)

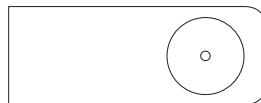

Towel Bar Post (2)

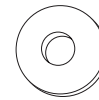

3/16" Flat Washer (6)

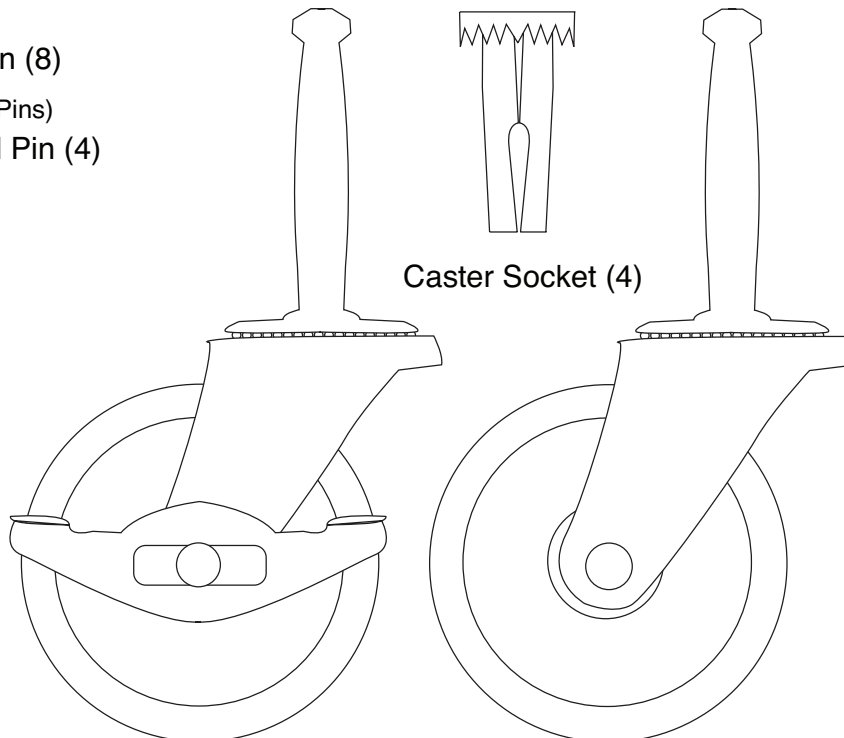

Caster Socket (4)

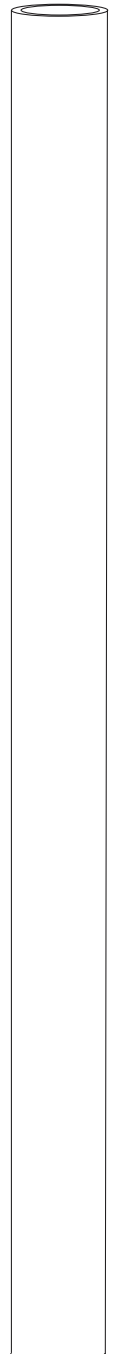

Towel Bar (1)

STEP 1

A. Tap/insert ONE 1 1/2" pin into each end of all the doors. DON'T OVERDRIVE PINS! Pins should stick up about 1/2" when seated.

B. Attach the magnet plate (may be stuck to magnet!) with the 1/2" #4 screw to the top of the doors. Bumps go toward the wood.

C. Attach door handles with 7/8" truss head machine screws.

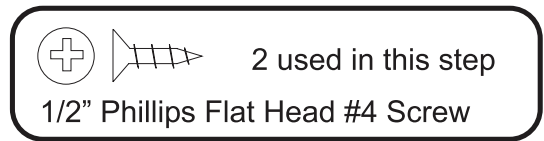
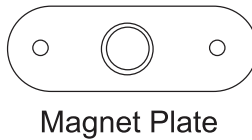
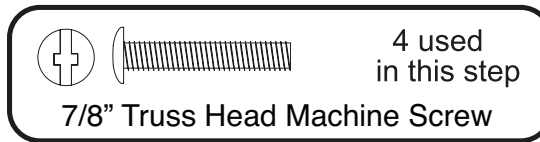
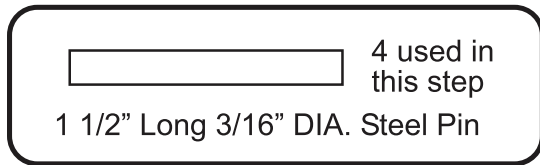
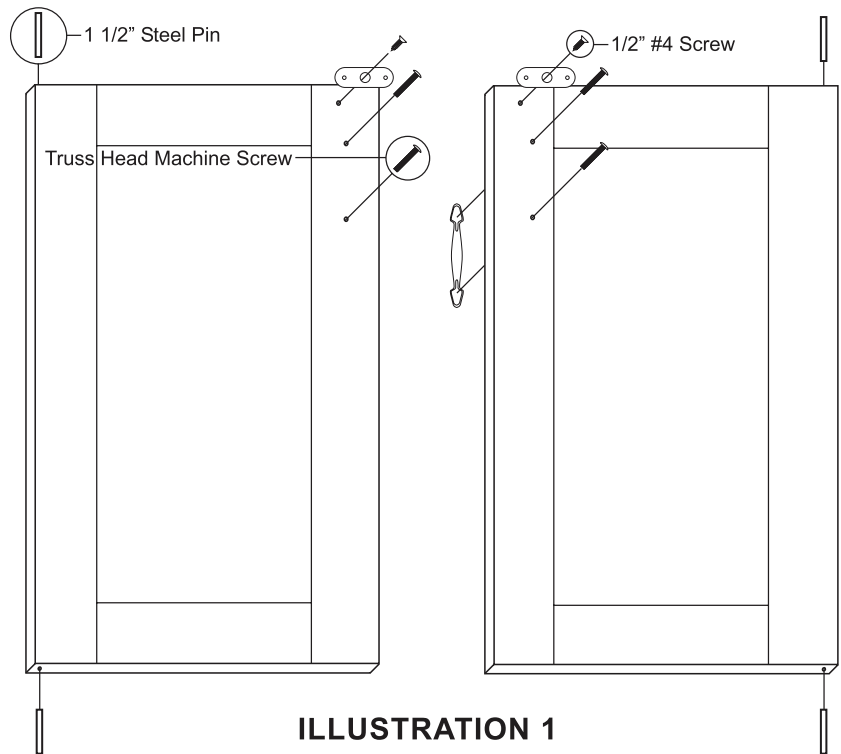

STEP 2

Assemble Spice Rack

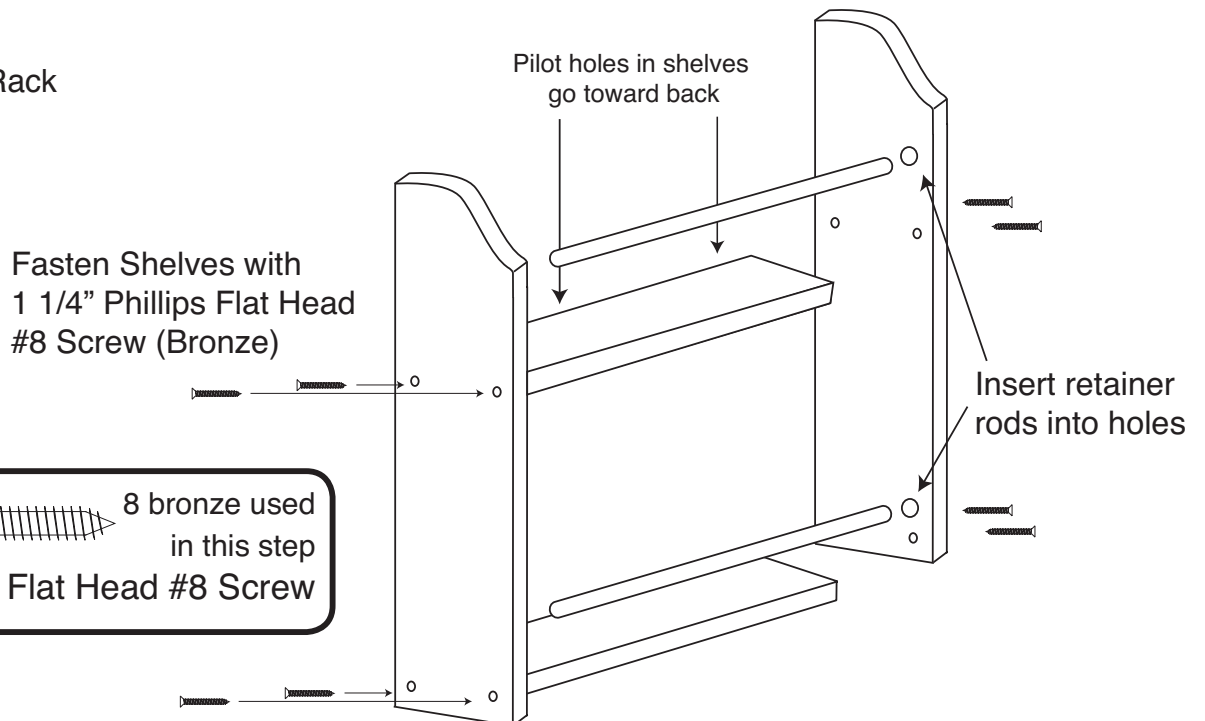

STEP 3

A. Attach the drawer back to the drawer sides with four 1 1/4" #8 screws. Make sure parts are aligned as in illustration 3A.

B. Insert drawer bottom into the slots in the drawer sides, best side to inside of drawer. Slide down until seated in the slot in the drawer back. See illustration 3B.

C. Screw the cam posts into the two outside holes on the inside face of the drawer front until seated. Only 3/8" of the post goes into the wood, leaving the 4 larger guide rings/head exposed. See illustration 3C. Visit us as www.catskillcraftsmen.com to view our cam video.

D. Insert the posts into holes in the drawer sides until seated against the front end of the drawer sides. Insert cams so that slot in the cam fits over the post and turn with Phillips screwdriver until seated. Don't over-torque! See illustration 3D.

E. Attach drawer handle with the two 1" Truss Head screws (no illustration).

F. Attach drawer glides to drawer sides using 5/8" #5 screws. See illustration 3E.

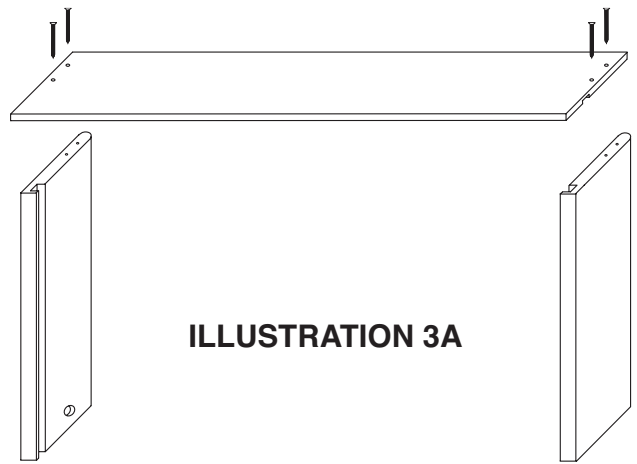

ILLUSTRATION 3A

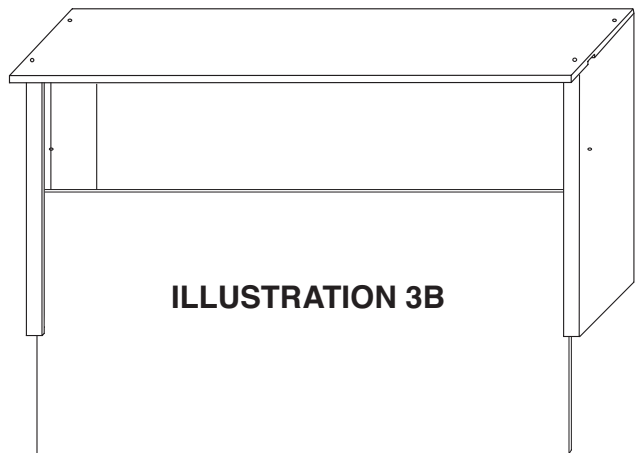

ILLUSTRATION 3B

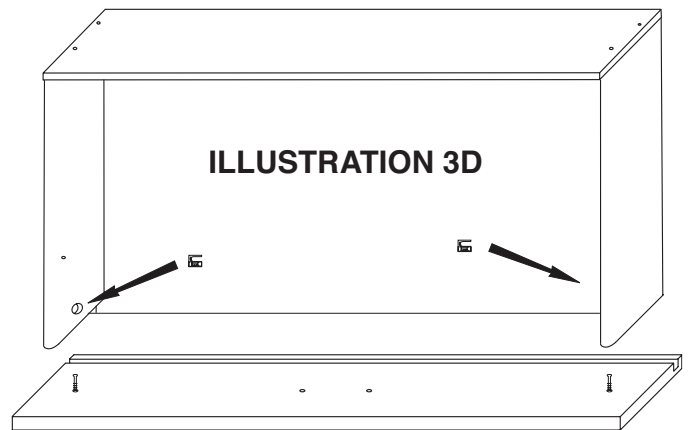

ILLUSTRATION 3D

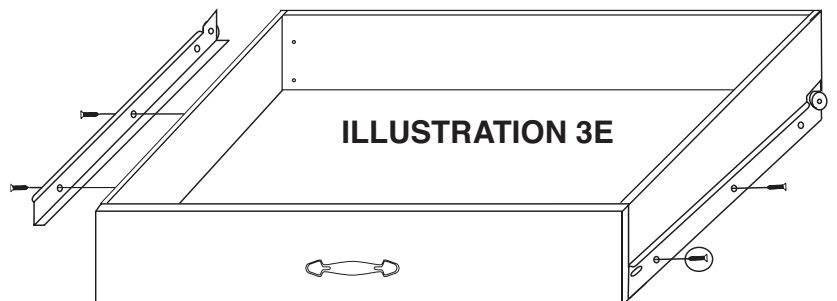
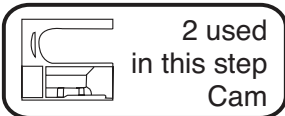
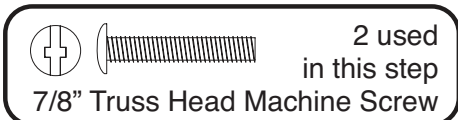
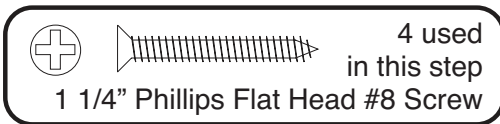
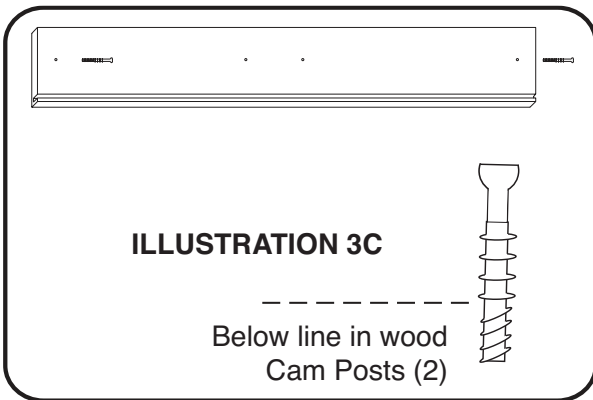

ILLUSTRATION 3E



STEP 4

Glide Support Assembly

The "L" brackets are attached to the Glide Support using the large slot in the "L" bracket. The Hole will be used to attach the table top.

Top of "L" Bracket should be even with the top of the glide support

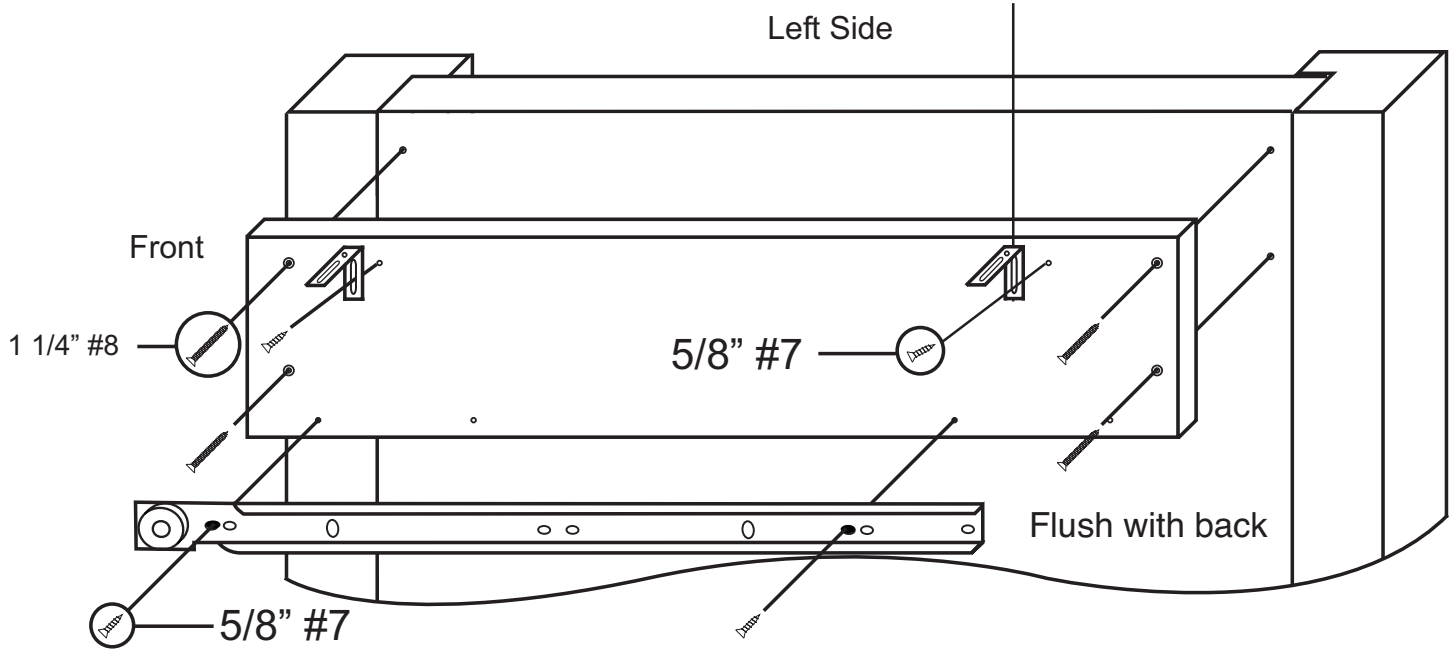

Right Side

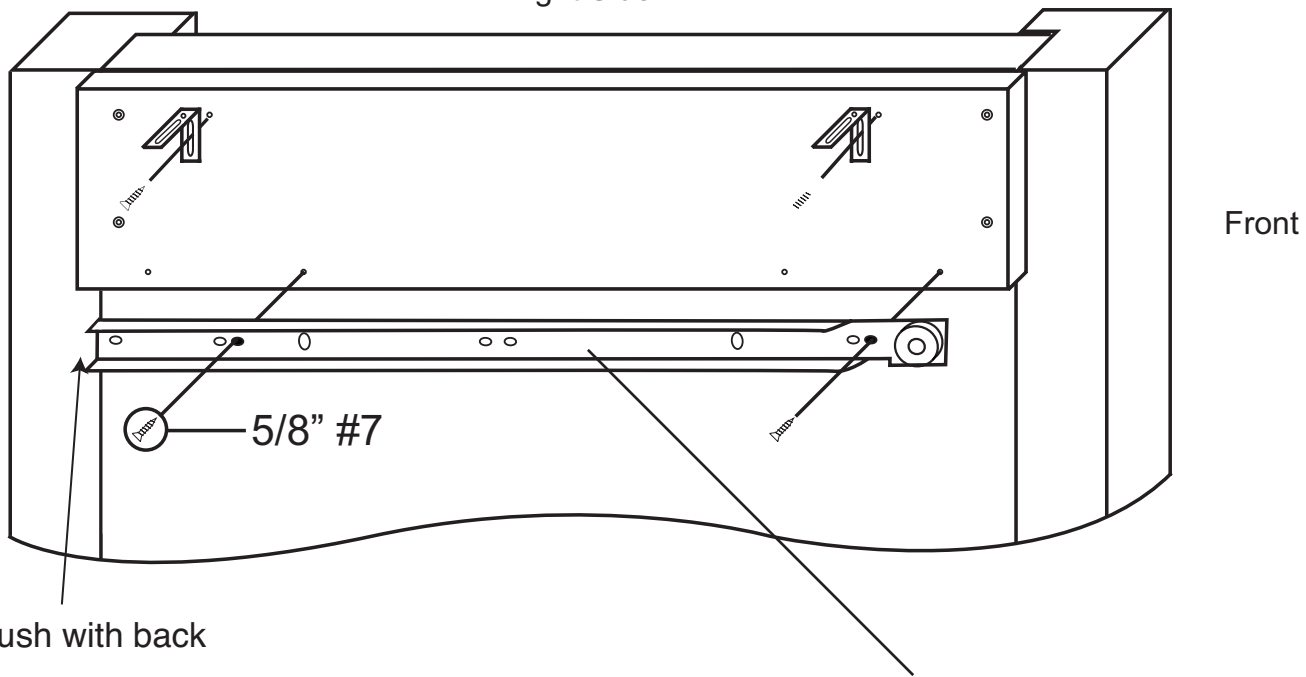

Note: Glide holes sometimes change, just make sure the cabinet glides are flush with the back of the glide supports & pilot holes will line up - only 2 holes are used!

The glides look almost alike; however, they are stamped CR for cabinet right and CL for cabinet left.

STEP 5

A. Lay back panel on a smooth surface with holes up.

B. Attach both side panels with 1 3/4" machine screws (bolts) and hex nuts. After inserting bolt(s) through the holes in the side panels, through the holes in the long edges of the back panel, place a hex nut on the top of your finger, align nut with bolt and tighten.

C. Look ahead to step 7 which shows side panels attached to back panel.

Note: Make sure you position the side panels according to drawer side (left or right).



4 Used in this step

1 3/4" Phillips Flat Head Bolt



4 Used in this step

10-24 Hex Nut

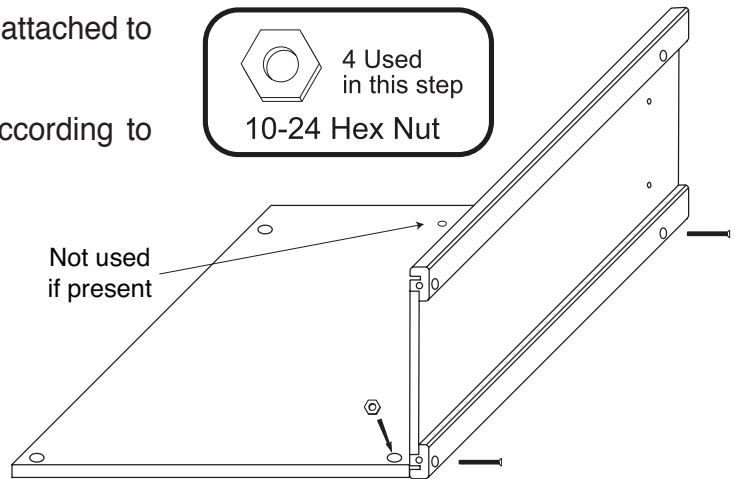
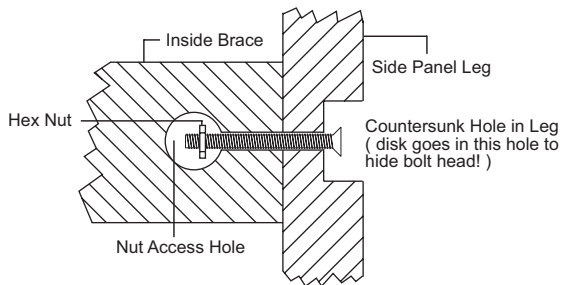

4 Used in this step
1" Long 3/16" DIA. Steel Pin

4 Used in this step
5/8" Phillips Head #7 Screw

STEP 6

A. Turn the side/back assembly (from step 2) upside down (invert) on top of the inverted table top.

B. Align the "L" brackets with the 4 inside pilot holes in the table top and secure with 5/8" #7 screws. The outer pilot holes will not be used with this model.

C. Tap two 1" pins into each side panel. These pins will hold the bottom shelf. See illustration 7.

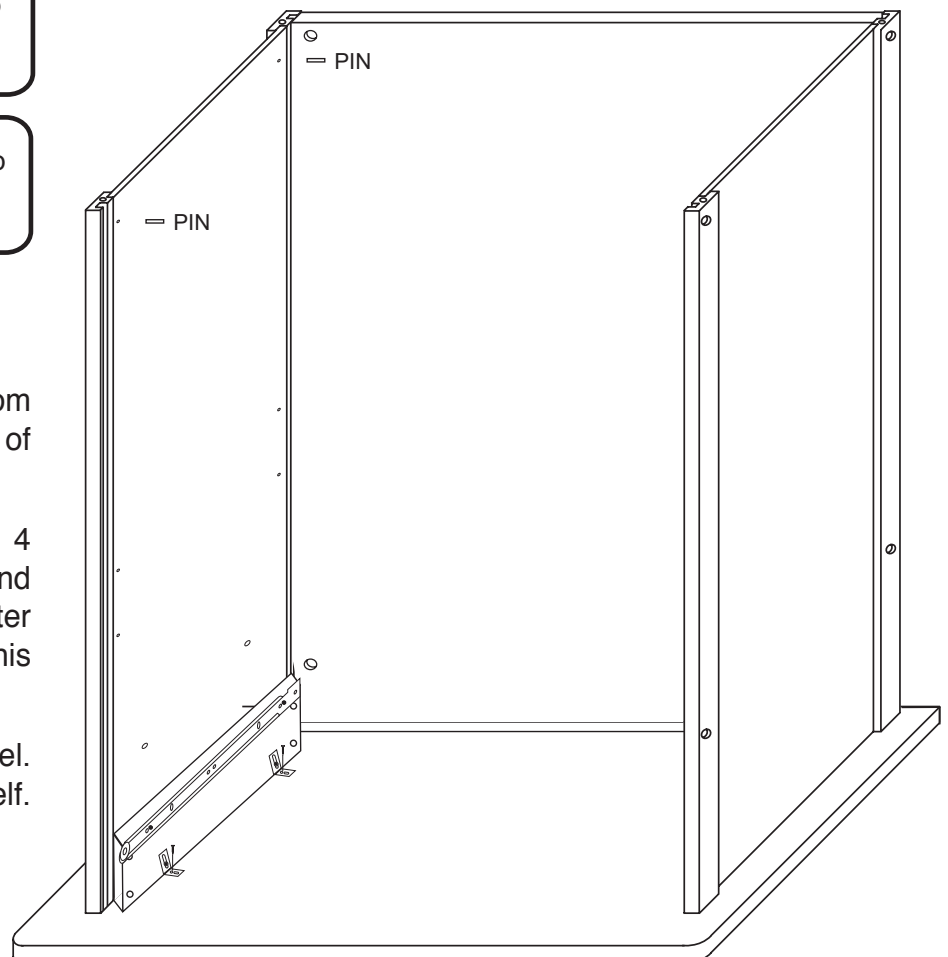

STEP 7

Take the 2 front braces and tap/insert one 3/4" steel pin into each end of both braces until seated. About 3/8" will stick out when seated. OK if loose.

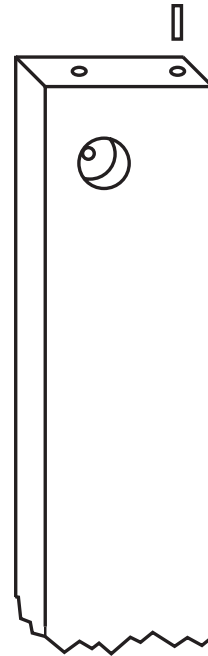
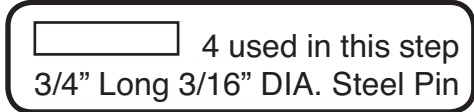

STEP 8

A. Take the top front brace (with magnet block), insert the pins in the brace ends into the slots of the inside of the front legs and slide down until the holes in the brace ends align with the holes in the front legs as in the illustration. The pin holes for the door pins will be up as will the magnet block.

B. Secure brace with 1 3/4" bolts and hex nuts.

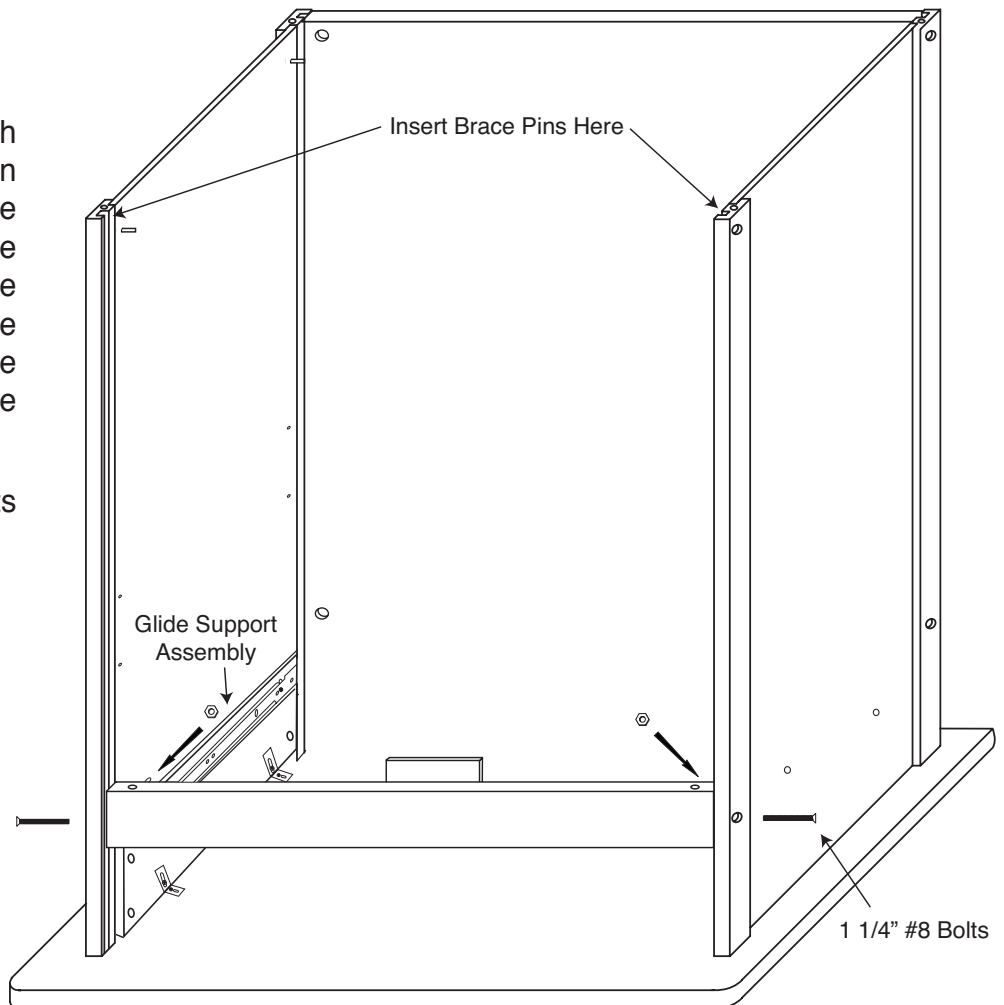
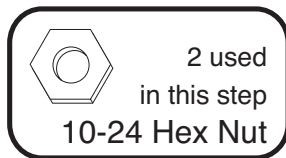

ILLUSTRATION 8



STEP 9

A. Install doors by inserting pins in the door tops into the holes in the long edge top front brace.

B. Place one washer on each pin in the door bottoms.

C. Take the bottom front brace, align pins in door bottoms with holes along top long edge of brace (are washers on pins?) and secure brace with 1 3/4" bolts/hex nuts as before.

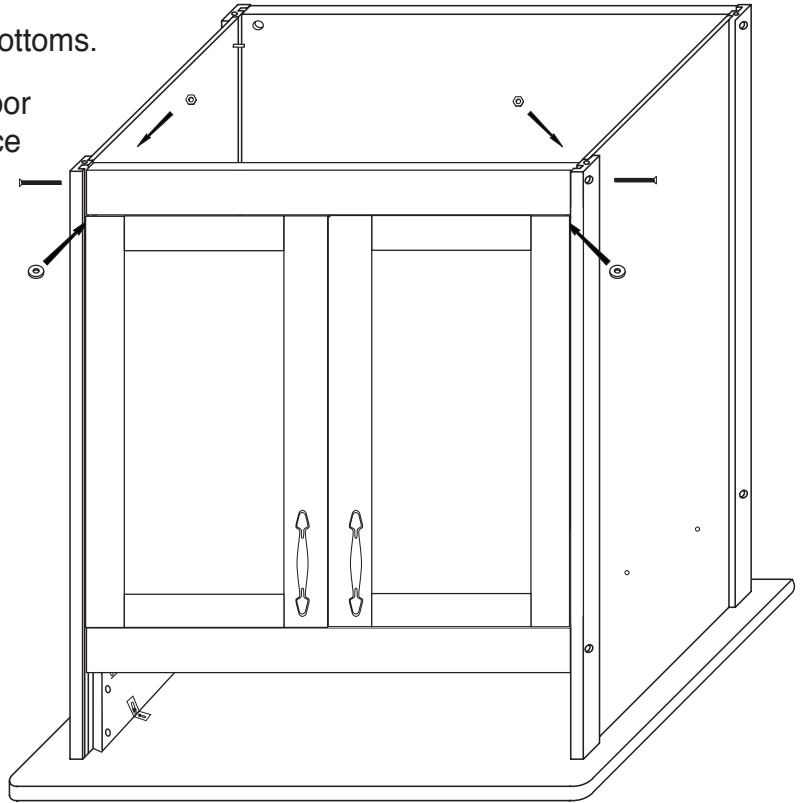
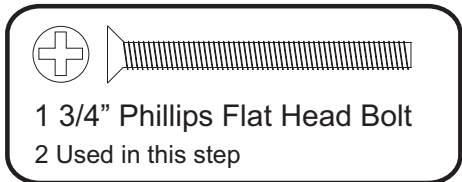
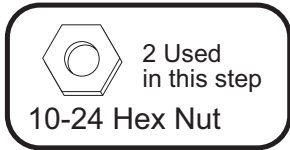

STEP 10

A. Stick magnet to magnet plate on right door.

B. With left door open, close the right door. The magnet should be positioned over the wooden block on the bottom of the top front brace. Hold the magnet in place with your thumb, and open the right door. The magnet will be in the correct position on the block.

C. Secure magnet with the two pan head screws in the magnet packet. Center screws in the slots in the magnet. This will allow adjustment later, if needed.

NOTE: No pilot holes in block as it is softwood!

D. Repeat with the left door.

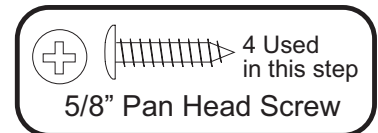
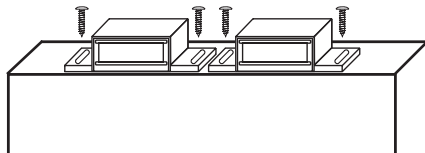

Magnet (2)

STEP 11

A. Insert and tap caster sockets with hammer until the teeth grab the wood. **DON'T POUND SOCKET FLAT OR CASTER SHAFT WILL NOT ENTER.**

B. Insert casters and seat by pushing straight downward with heel of your hand, or tap into place with a hammer. Don't be afraid to give them a good downward whack on the solid metal part of the caster!

C. Locking wheels usually go on back, but can go diagonally or on the front if cart is moved a lot.

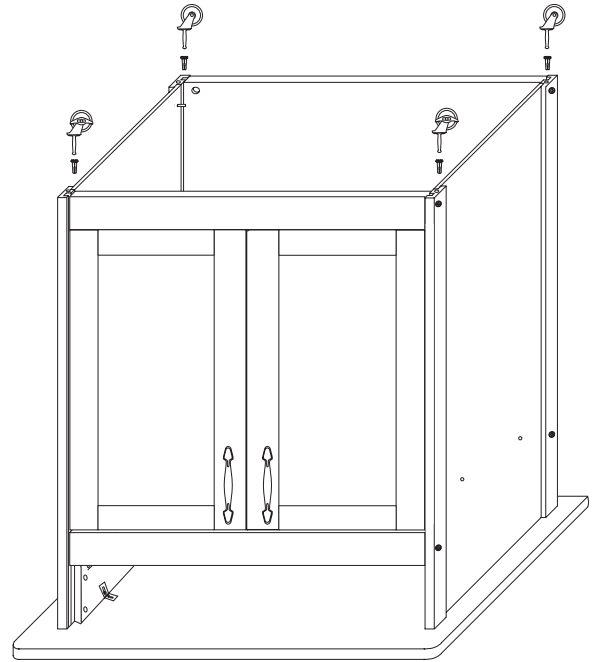

STEP 12

Decide which side you want the towel bar on. Place a washer on the 1" #8 screws and attach handle/towel bar to either side panel from inside the side panel.

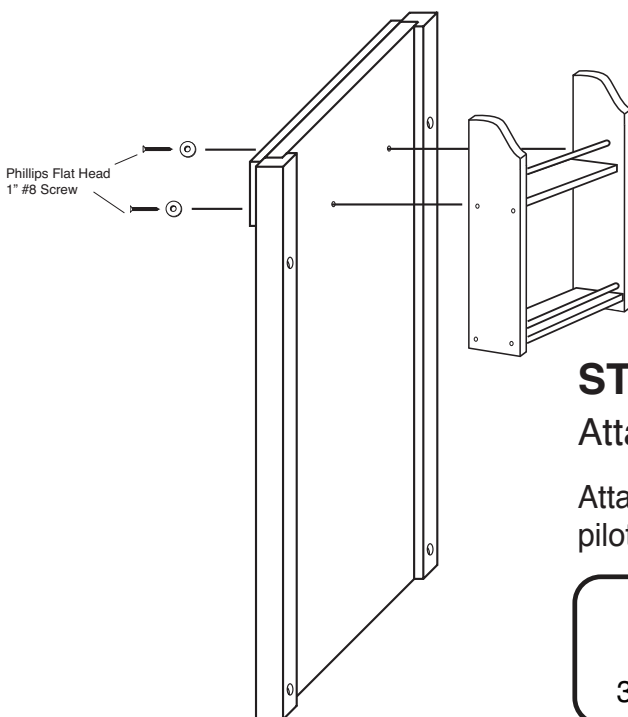
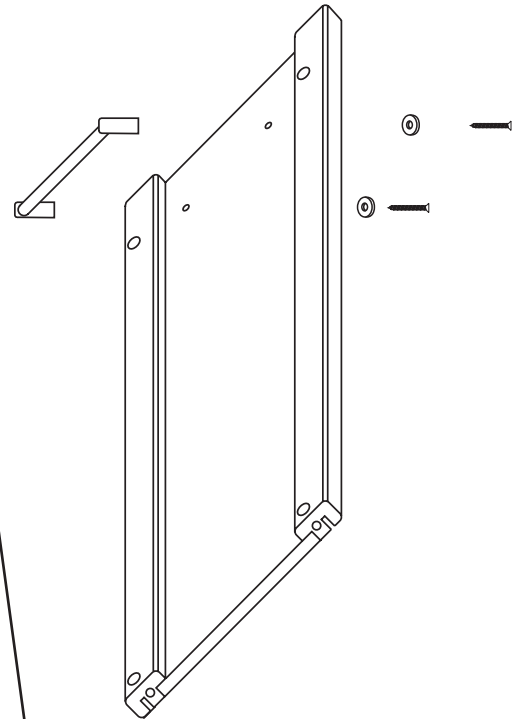

STEP 13

Attach Spice Rack to Side Panel

Attach the spice rack to the other side using 1" #8 screws into pilot holes in top shelf. Place washer over screws first.

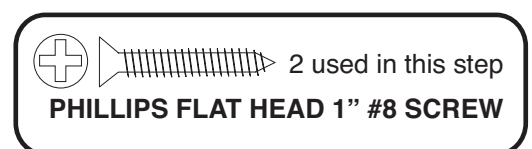
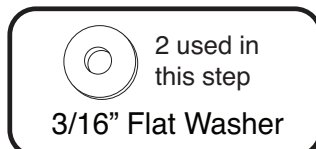

STEP 14

A. Upright unit. Take bottom shelf (no edge banding) and place it on the set of back pins. Close doors and shelf will drop into place.

B. Decide on position of middle shelf, then tap two 1" pins into each side panel, making sure the pins on both sides are in the same relative position. To remove a pin, use pliers or claw hammer.

C. Place middle shelf, edge banding out, on pins.

D. Insert drawer.

Note: If the top edge of the drawer front hits the underside of the cart top or the top edge of the top front brace, loosen the machine screws in the top front brace a little and adjust brace down until drawer opens/closes freely - check to make sure doors open/close freely.

E. Re-tighten all bolts/nuts.
Tap wooden disks into sides.

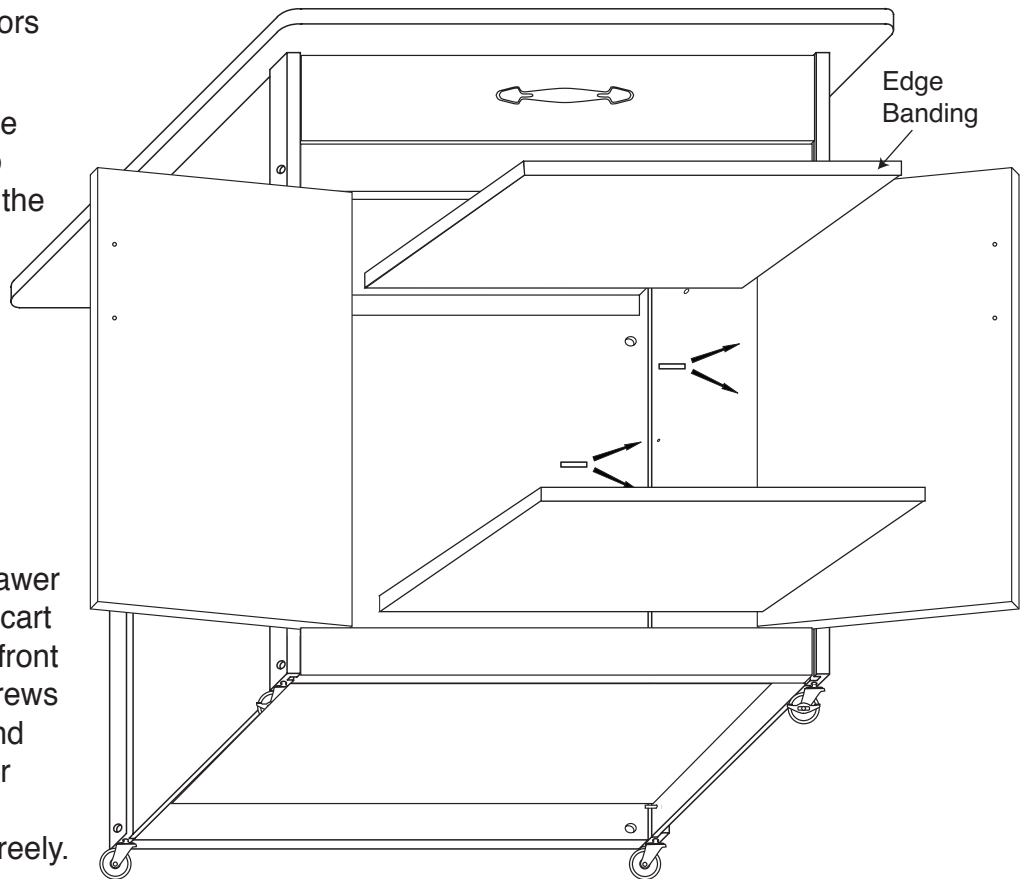
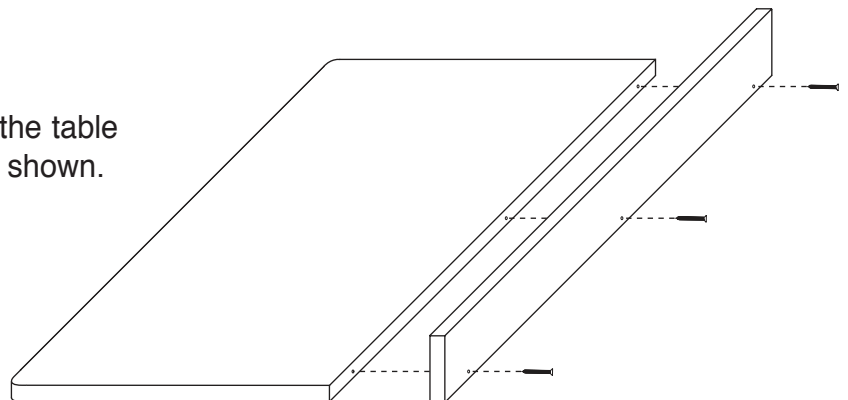
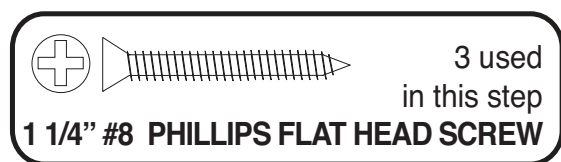

ILLUSTRATION 15

STEP 15

Assemble Backsplash

Attach the backsplash to the back edge of the table top with 1 1/4" #8 screws in three places as shown.





For continued beauty and long life of your Catskill Craftsmen cart, we recommend Catskill Craftsmen's Butcher Block Oil. Our Butcher Block Oil is available directly from Catskill Craftsmen's factory. For one eight ounce (8 fl. oz.) bottle, which is sufficient for two applications, simply send \$7.95 along with the completed coupon to the address below. Visit us online at www.catskillcraftsmen.com to browse our assortment of butcher block care products. Visa and Mastercard are accepted online.



Catskill Craftsmen, Inc.
15 West End Ave.
Stamford, NY 12167-1296



BUTCHER BLOCK OIL COUPON

Please send me _____ # of bottle(s) of the Catskill Craftsmen Butcher Block Oil at \$7.95 per bottle. My check or money order is enclosed for a total of \$_____.

Item code: 61533

Name _____

Address _____

City _____

State _____ Zip _____

Please make checks payable to Catskill Craftsmen Inc.
15 West End Ave., Stamford, NY 12167-1296