

CATSKILL

C R A F T S M E N , I N C .

Assembly Instructions Model 64024 The Deep Storage WorkCenter



A. These units are Ready-to-Assemble. Catskill uses positive fastening methods such as wood screws and in some places hidden Bastion fasteners. You will need some standard household tools: hammer and Phillips small and medium screwdrivers. A power screwdriver is recommended for some applications. Where possible, we have packaged some of the screws in separate labeled packages. Note label for screws and when they are to be used in assembly in the instructions.

B. Directions (left/right, front/back) are given as facing the front of an assembled upright unit.

C. A friend is recommended to assist with assembly as this will ease the process. Some of the parts are large and awkward to hold in place, and an extra pair of hands will help.

D. Visit www.catskillcraftsmen.com to view our assembly video and care products.

PARTS 64024

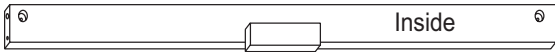

P/N: B-27/2/64024/TF
Top Front Brace (1)

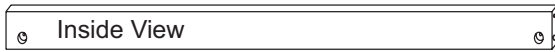

P/N: B-27/2/64024/BF
Bottom Front Brace (1)

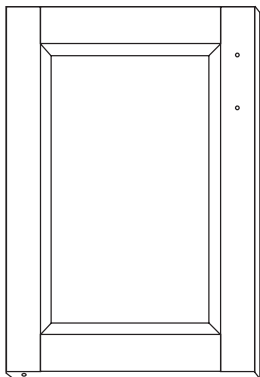

P/N: DOOR-64024L
Left Door (1)

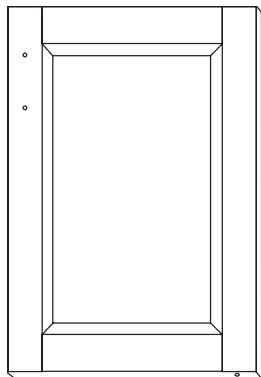

P/N: DOOR-64024R
Right Door (1)

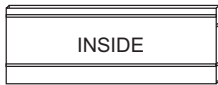

P/N: SIDE SHELF-64024
Side Shelf (8)

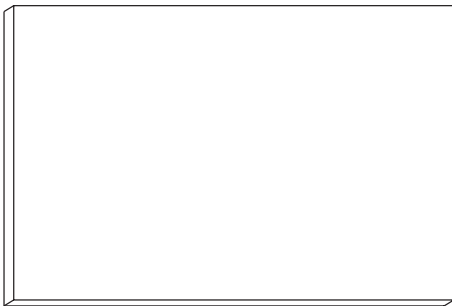

P/N: 64024/BOT
Bottom Shelf (1)

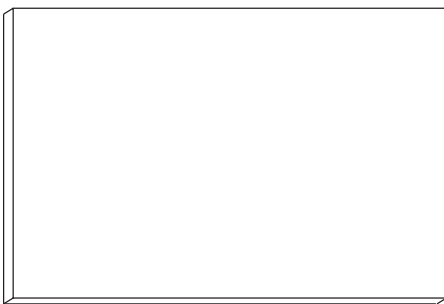

↑ EDGE BANDING ↑
 P/N: 64024/MID
Middle Shelf (1)

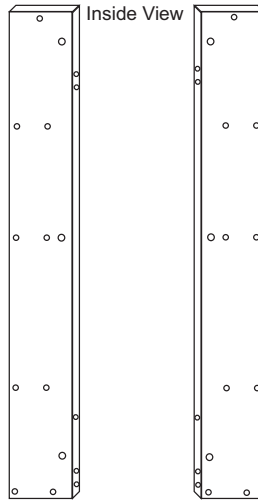

P/N: L-31/5/RF/64024 P/N: L-31/5/LF/64024
Front Legs (2)

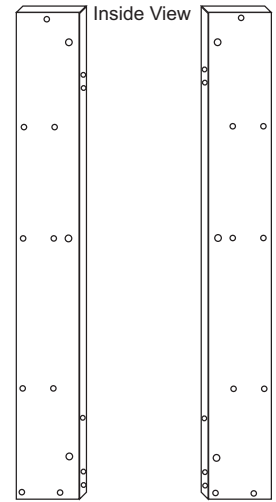

P/N: L-31/5/LB/64024 P/N: L-31/5/RB/64024
Back Legs (2)



P/N: DS-18R 64024
Right Drawer Side (1)



P/N: DS-18L 64024
Left Drawer Side (1)



P/N: TT 64024
Table Top (1)

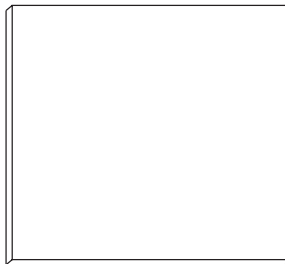

P/N: DBOT 64024
Drawer Bottom (1)



P/N: DBK 64024
Drawer Back (1)

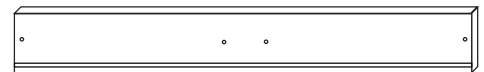

P/N: DF 64024
Drawer Front (1)

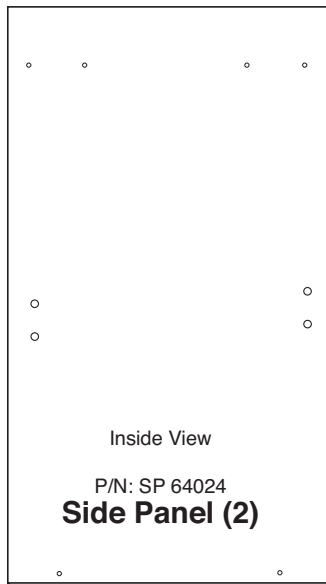

Inside View
 P/N: SP 64024
Side Panel (2)

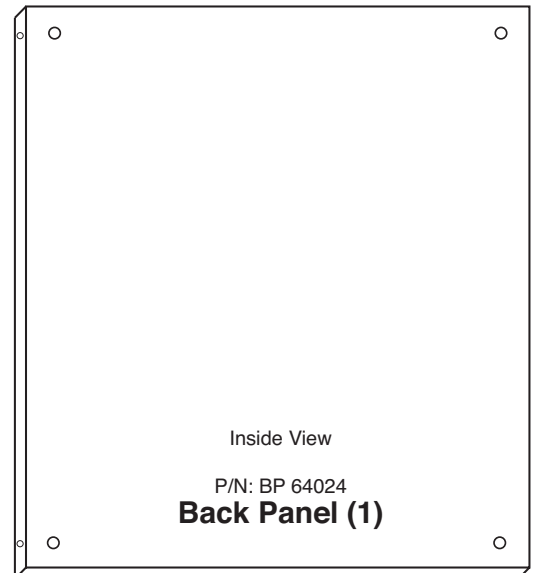

Inside View
 P/N: BP 64024
Back Panel (1)

Hardware 64024

IMPORTANT NOTE ON SCREWS: Separate screws into piles with a note on use as some are very similar. **DO NOT** use the larger diameter 5/8" #8 screws to attach the drawer glides. Screws for the glides have flat heads & are much smaller in diameter. Double Check!!

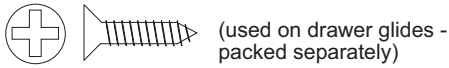

(used on drawer glides - packed separately)
5/8" Phillips Flat Head #6 Screw (4)



(used to attach butterfly bracket)
5/8" Phillips Flat Head #8 Screw (8)

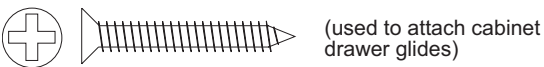

(used to attach cabinet drawer glides)
1" Phillips Flat Head #6 Screw (4)



1 1/2" Phillips Flat Head #8 Screw (16)



(used on door/drawer handles)
1" Truss Head Machine Screw (6)



(Brace pins)
3/4" Long 3/16" DIA. Steel Pin (4)



(Shelf pins)
1" Long 3/16" DIA. Steel Pin (40)



(Door pins)
1 1/2" Long 3/16" DIA. Steel Pin (4)

Magnet Pack



Magnet (2)

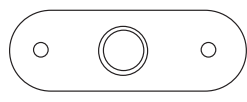

Magnet Plate (2)



(Used on Magnet Plate)
1/2" Phillips Flat Head #4 Screw (2)

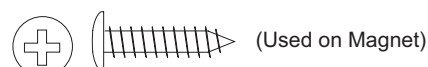

(Used on Magnet)
5/8" Pan Head Screw (4)

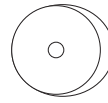

P/N: SPACER

Plastic Spacer (4)

(Goes between cabinet drawer glide & side panel)

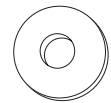

3/16" Flat Washer (2)



P/N: B-NUT

Bastion Barrel Nut (10)



P/N: SET SCREW

Bastion Set Screw (10)



P/N: B-POST

Bastion Post (10)

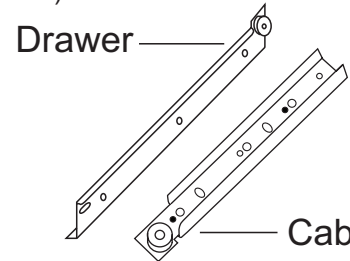

Drawer Glide (1 Set)



5/8" Wooden Disk (12)

(Packed with Hardware)

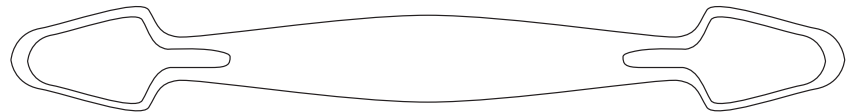

P/N: HANDLE 64024

Nickel Handle (3)

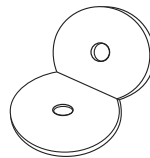

Butterfly Brackets (4)

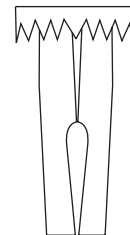

Caster Socket (4)

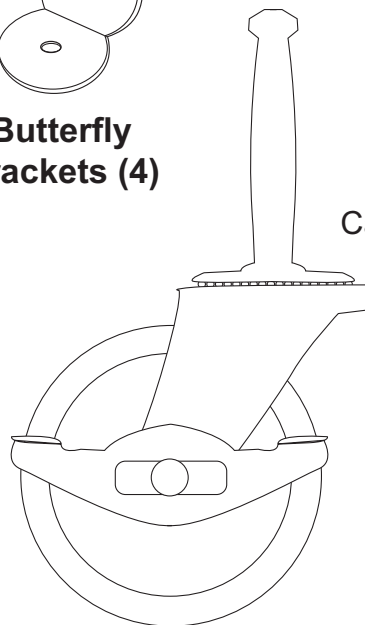

P/N: WHEEL 2L (LOCKING)

Locking Wheel Casters (2)

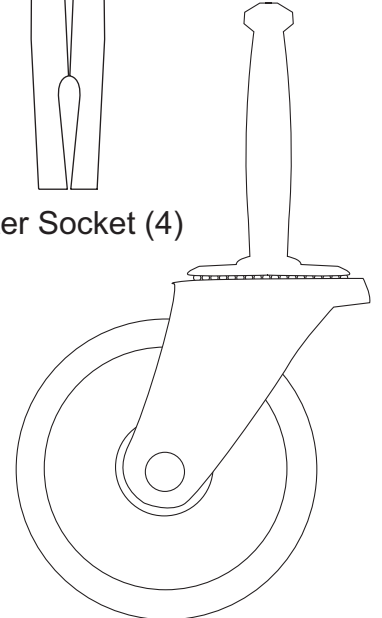

P/N: WHEEL 2 (NON-LOCKING)

Wheel Casters (2)

STEP 1

Assemble Drawer

A. Attach the drawer back to the drawer sides with four 1 1/2" #8 screws. There are left and right sides. Make sure the slots that run the length of the sides are aligned with the slot in the drawer back to accept the drawer bottom.

B. Slide in drawer bottom, best side up to inside of drawer.

C. Take 2 bastion posts, align the threaded end of the posts with the post holes located near the ends of the inside of the drawer front. Tighten posts down until the solid shaft of the post hits the wood. Back post out about 1/2 turn until the hole/screwdriver slot in the end of the post is parallel and in direct line with the long edges of the Drawer Front. Dip threads in cooking oil to ease turning.

D. Insert the barrel nuts into the nut access holes on the inside of the drawer side with the threaded end of the nut facing out. Take the drawer front and carefully insert the posts into the ends of the brace sides, through the sides of the nut until seated. Push nut snug up against the wood in the nut access hole toward the inside drawer front. Hole should be slightly off-center toward the drawer front. Insert the set screw and tighten down with a Phillips screwdriver. See illustration. The ends of the sides should be tight against the inside drawer front. See Bastion video on our website www.catskillcraftsmen.com

E. Attach the drawer handle with the M 8-32 Pan Head Machine Screws.

F. Attach the drawer glides (left and right) to the Drawer Sides using two 5/8" #6 screws per side. Wheels go toward drawer back and are up.

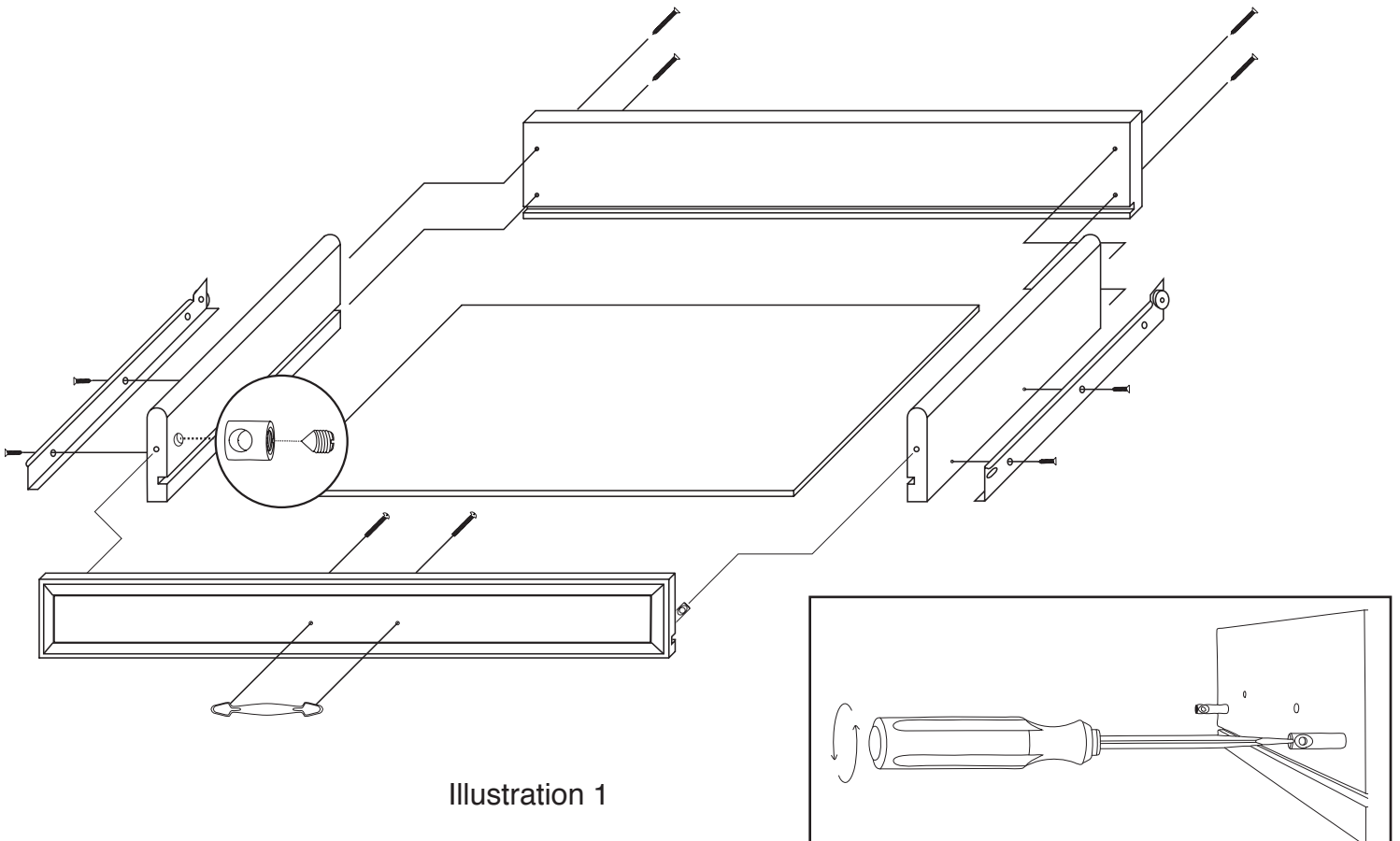

STEP 2

Attach Posts To Legs

A. There are 2 right legs and 2 left legs. Diagonal legs are the same (Example: Right Front /Left Back). See Illustration 2 below which shows the legs paired (inside view) for the front and back panels respectively. Notice that the position of the posts in the front legs differ from those in the back legs. This difference will mean that there are some holes that are not used on all legs.

B. Take all 4 legs and lay out in pairs as in Illustration 2. Each pair of legs should be mirror images of each other! Make sure the bottoms of the legs (hole in each of legs for caster is bottom) are down as they are in the illustration.

C. On the Front Legs, posts will go into holes #1 and #5 counting down from the top. On the Back Legs, posts will go into holes #1 and #3. On the Front Legs, hole #3 is not used. On the Back Legs, holes #4 and #5 are not used.

D. To seat posts, tap the slotted end of posts with hammer until threads just enter holes; then tighten down (see "Tips On How The Bastion System Works" for alternative methods) until the solid shaft of the post hits the wood, then back at least 1 full turn so that the hole in the post is perpendicular to the length of leg/wood grain. Screw posts into all 4 legs. Double check with Illustration 2.

INSIDE VIEW

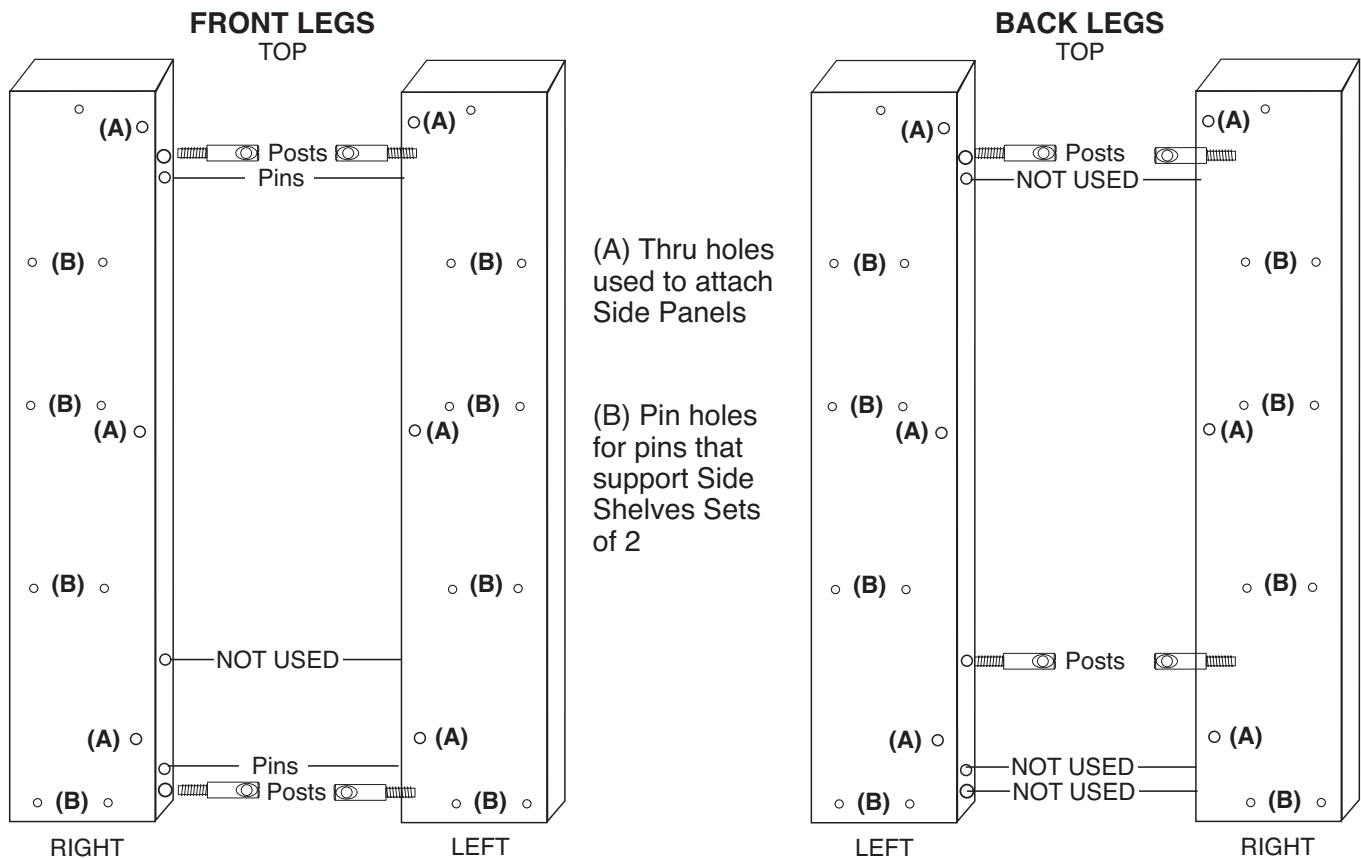

Note: Only the post holes are used on Back Legs.

Illustration 2

STEP 3

Assemble Cabinet Back

A. Take the Back Panel and the Back Legs, lay out as in illustration 3. The Back Panel cannot be installed improperly since the top and bottom hole measurements are the same distance top to bottom.

B. Drop a Barrel Nut, open end up, into each of the large nut access holes in the Back Panel. There are small indented marks on the lip of the open end of the Barrel Nut. This shows the alignment of the holes through the sides of the Back Panel. Continue seating Post until Post goes thru the sides of the Barrel Nut and the hole in the post can be seen through the threaded end of the nut. When the back panel is flush against the inside of the leg, the hole in the post should be offset toward the side of the access hole adjacent to the post. Insert the Set Screw and tighten down with Phillips screwdriver. Set Screws should thread easily. **DO NOT CROSS THREAD OR FORCE.** As you tighten the Set Screw down, the tip of the screw will seek the center of the hole in the post, thereby pulling the side of the Barrel Nut against the inside edge of the access hole and toward the leg. If the nut is loose and does not tighten down against the wood after the Set Screw is tightened then you will need to remove the leg(s) and tighten the Bastion Post down another 1/2 turn, then repeat above.

C. Attach Right Leg to Back Panel in the same manner. Illustration 3A shows the assembled Back Panel.

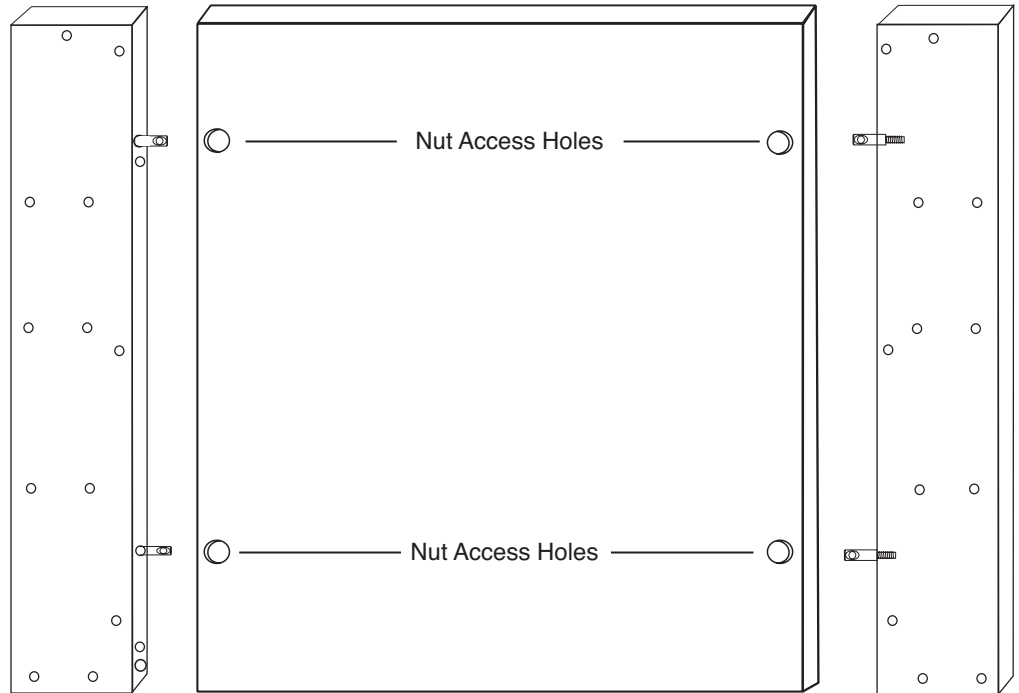

Illustration 3

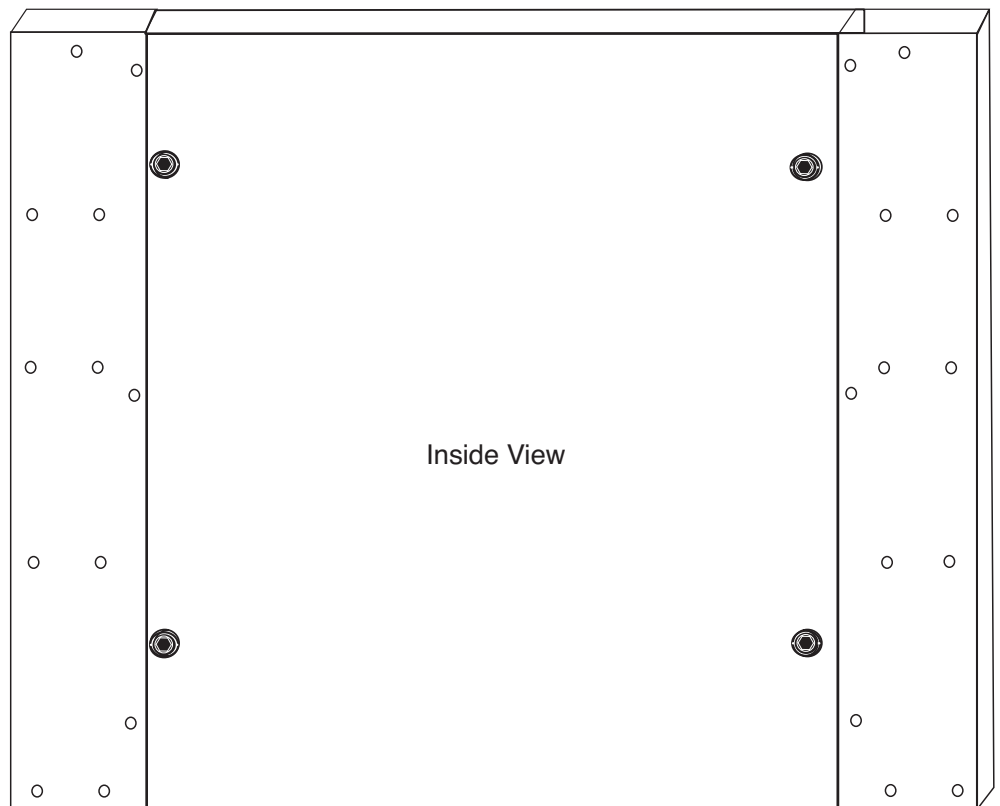

Illustration 3A

STEP 4

Assemble Cabinet Front

A. Prep doors by inserting 1 1/2" pin in the top/bottom of each door. Attach the magnet plates to the top of each door using pilot holes in door and small flat head screw in the magnet pack. Bumps on the magnet plate face the wood.

B. Take the 2 Front Braces (Illustration 4) and tap/insert one 3/4" pin into each end of each brace. Take the 2 doors and tap/insert one 1 1/2" pin into each end of each door. With pins in place lay out Braces, Doors and Front Legs as illustrated in Illustration 4A.

C. Place 1 washer on each bottom door pin. Push door pins into the Bottom and Top Front Braces until seated. Drop Barrel Nuts into the nut access holes in the legs. Next, attach this door assembly to the Left Back Leg with Bastions/Pin. Then attach the Right Back Leg in the same manner (as shown in Step 2). Illustration 4B shows an assembled cabinet front.

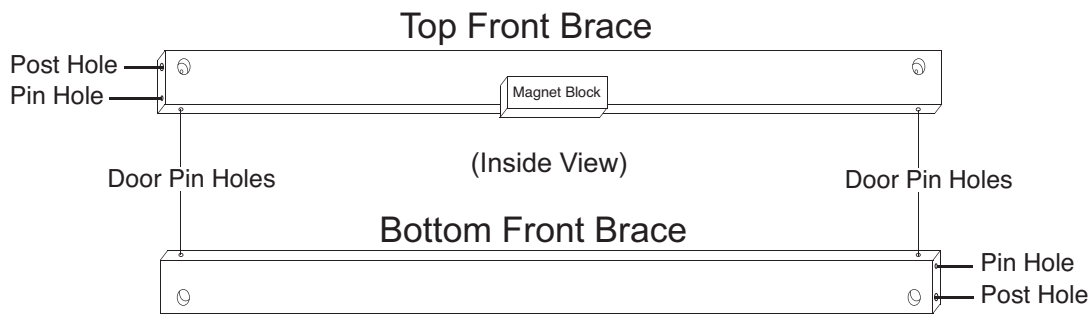

Illustration 4

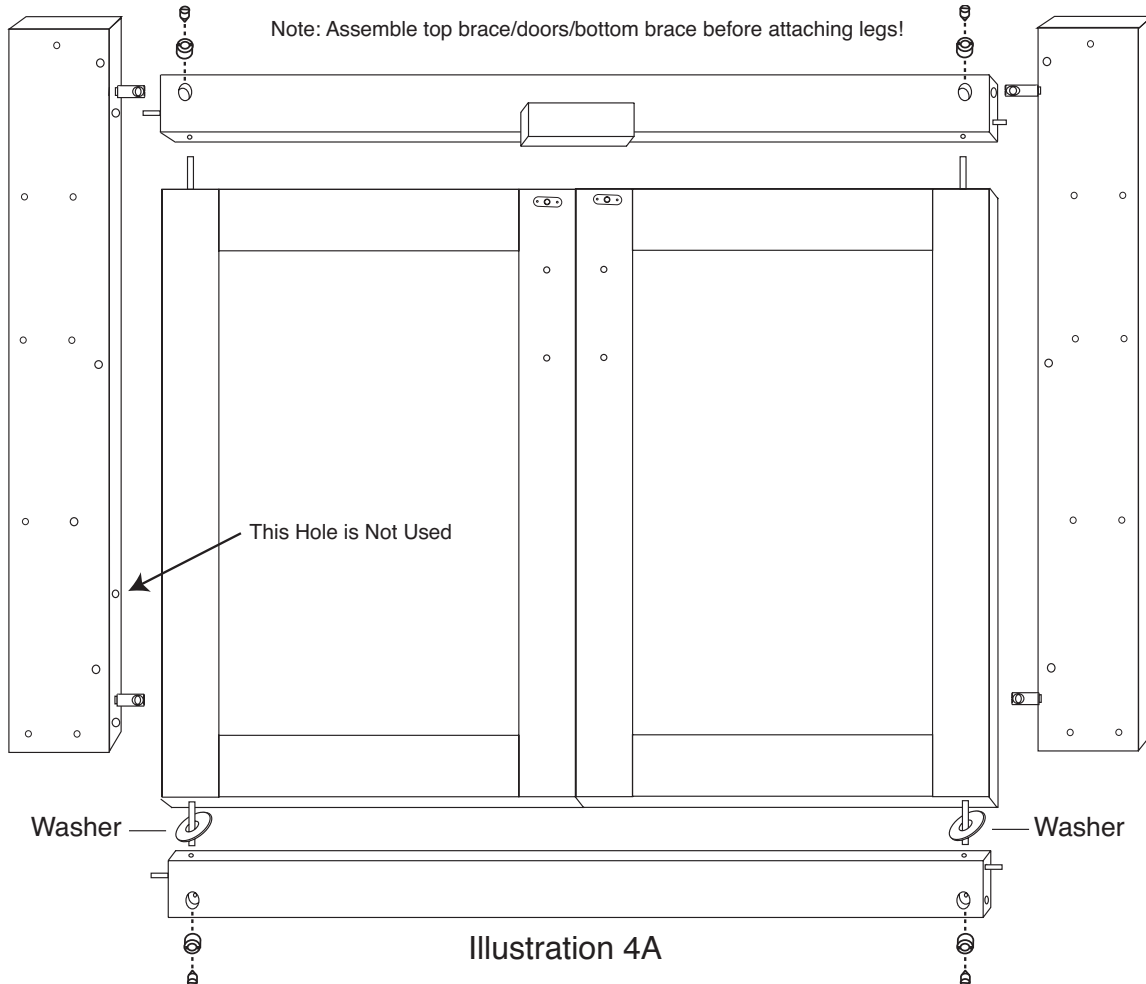

Illustration 4A

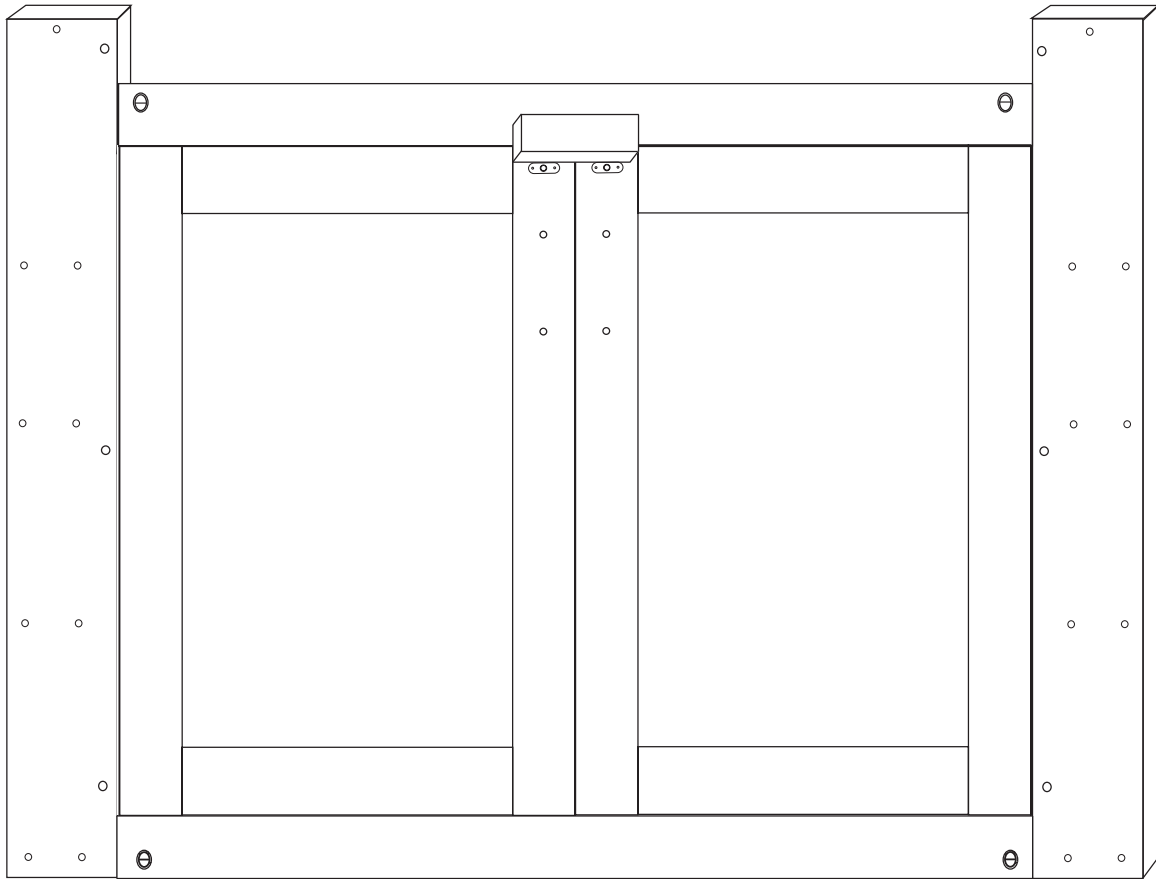

Illustration 4B

D. Invert the Front Cabinet Assembly. Attach the magnet plates to the inside top of the doors using flat head 1/2" #4 screws. Stick the magnets to the magnet plates on the Doors. The Magnet should be positioned over the wooden block on the bottom of the Top Front Brace. Secure the Magnets with the two Round Head Screws in the magnet packet. Center screws in the slots in the magnet. This will allow adjustment later, if needed. The block is soft wood, so no pilot holes are needed.

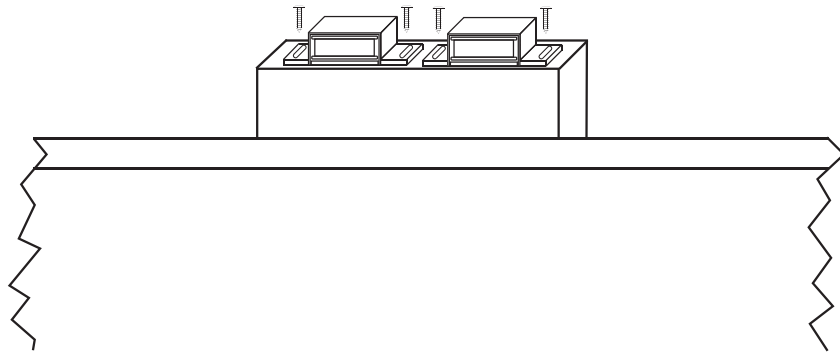

Illustration 4C

STEP 5

Attach Front Assembly to Back Assembly with Side Panels

A. This step is easier with 2 persons! Take the front assembly and attach the 2 side panels with three 1 1/4" screws per side. Push screws through the three holes on the front face of each leg, aligning the screws with the pilot holes in the long edges of the panels. Start all three into the pilot holes, then tighten them down. Repeat with the other side panel. Illustration 5 shows side panels in place attached to the front assembly.

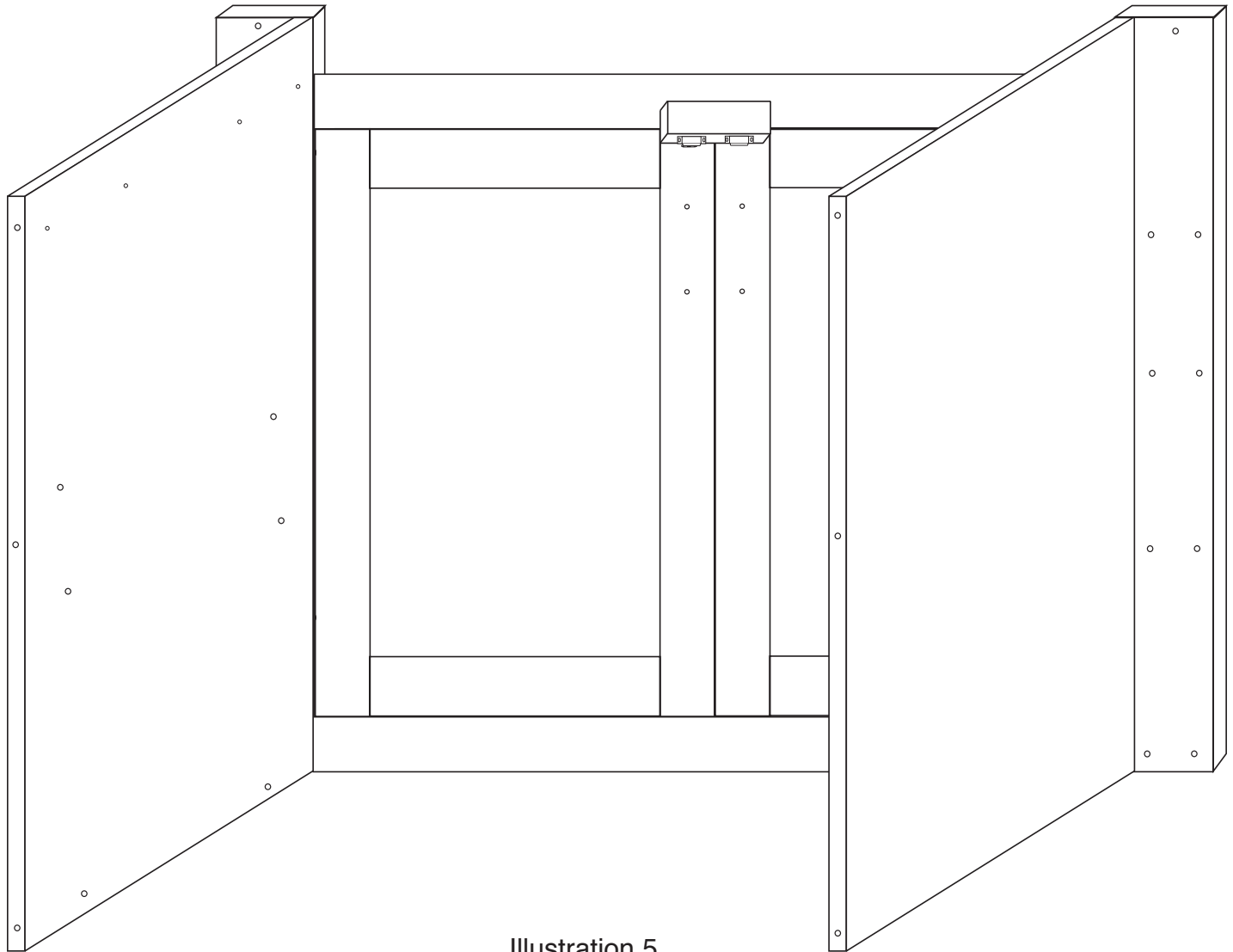

Illustration 5

Attach back panel with 1 1/2"
Phillips Flat Head #8 Screws

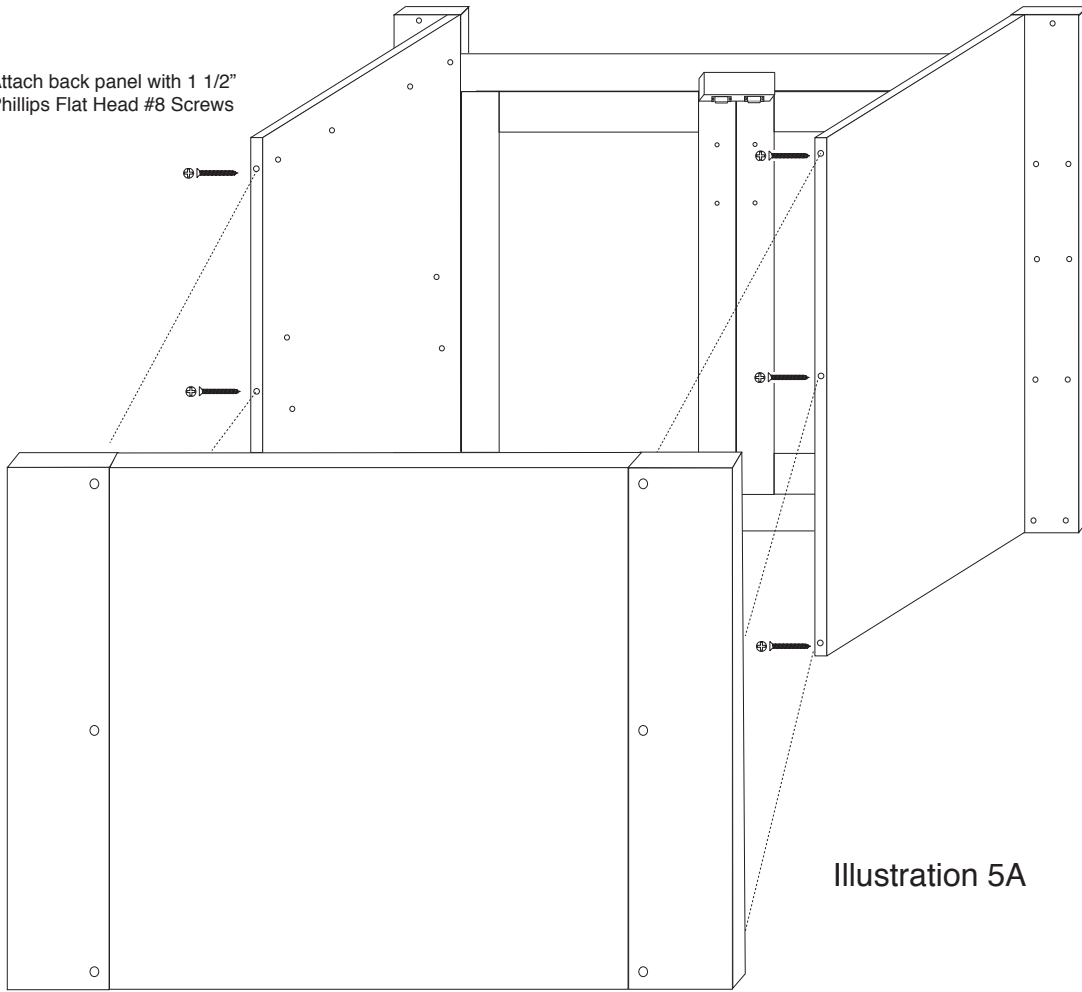

Illustration 5A

B. Take the back assembly and attach it to the side panels using three 1 1/2" #8 screws as above. Illustration 5A shows back panel assembly going into place. Illustration 5B shows cabinet assembly at this point.

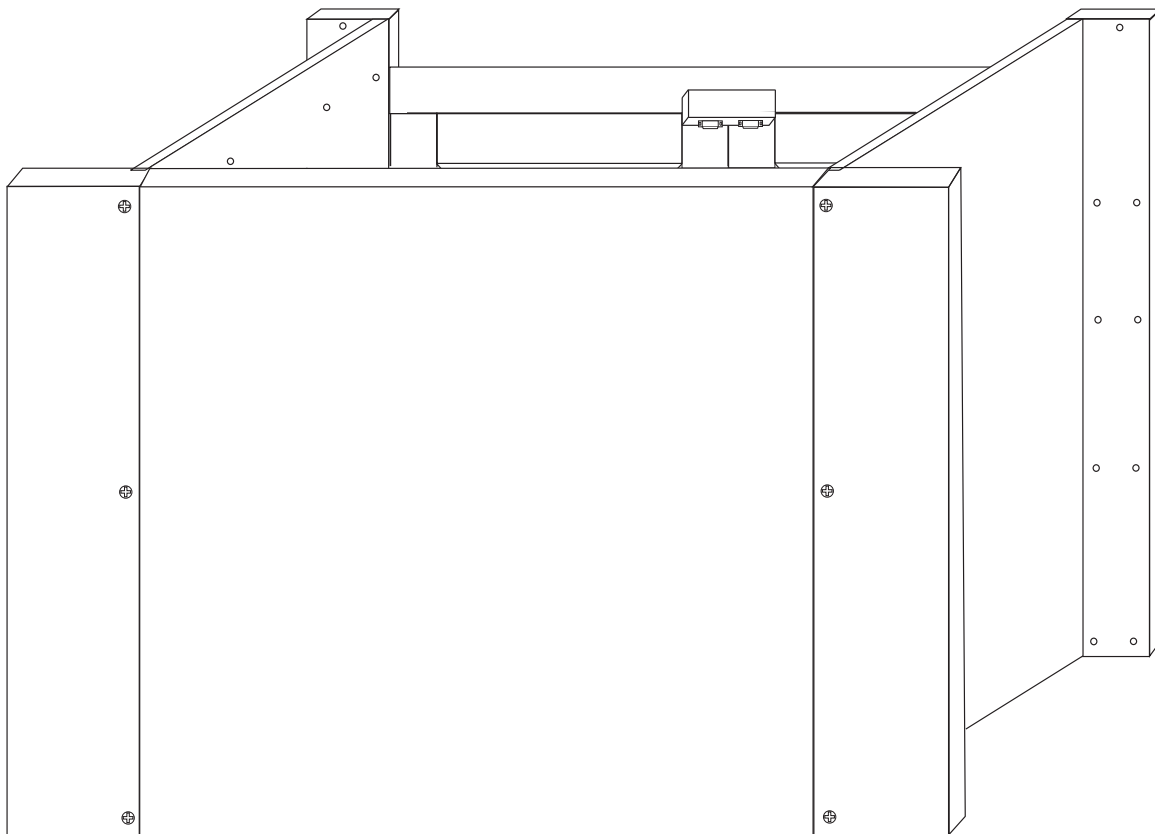
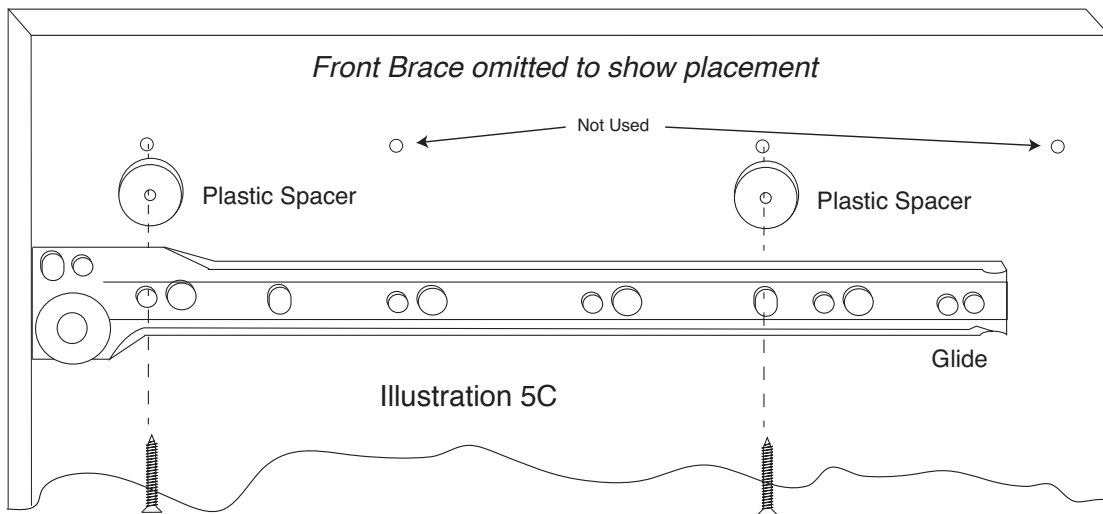
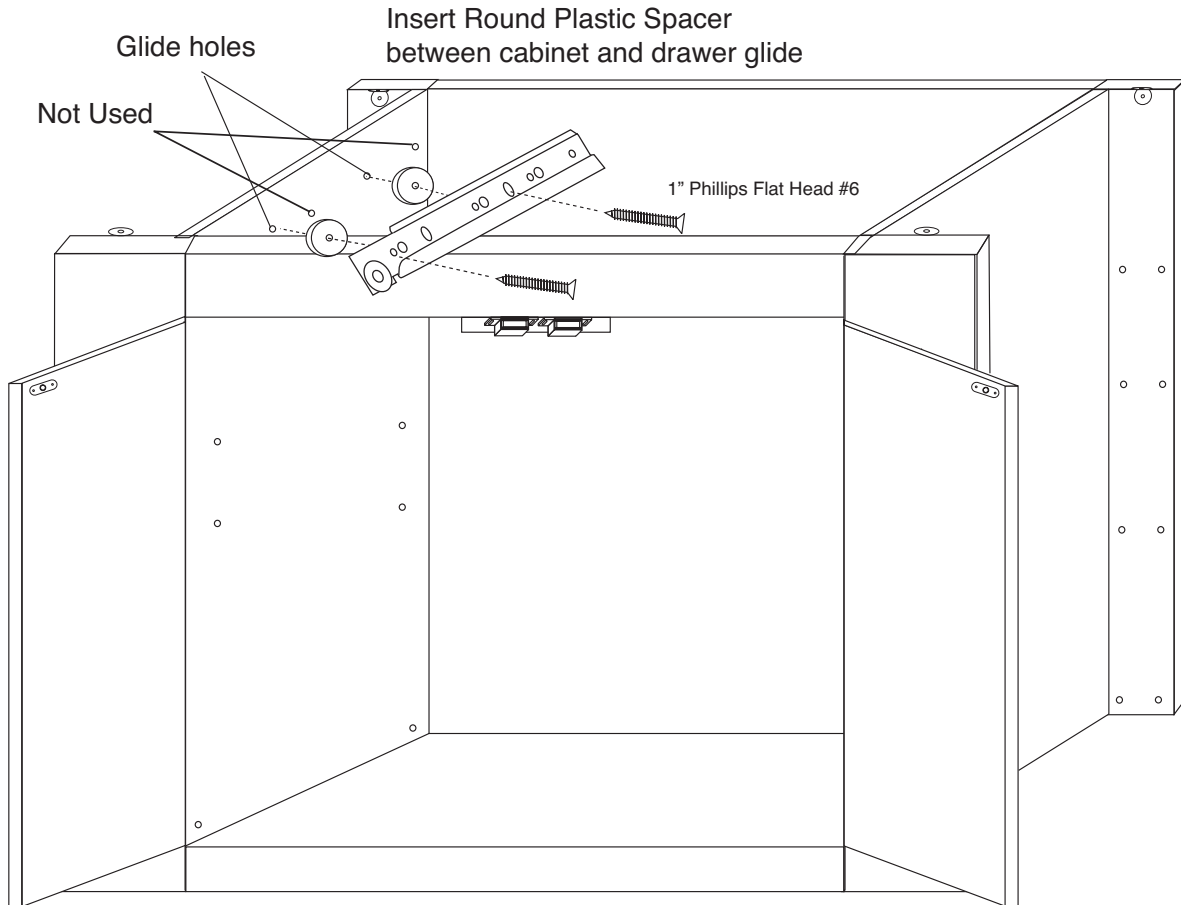

Illustration 5B

C. Attach the drawer glides to the side panels using 1" #6 screws and round plastic spacers. See Illustration 5C to locate holes. See Illustration 5C for glide attachment guide. Make sure you have the right screw (this is the small diameter screw).

Note: Although there are 4 holes in our side panels for glide screws, use holes 1 and 3 front to back.

D. Attach a butterfly bracelet to the top of each leg using 5/8" #8 screws.



Note: Drawer glides are flush with front edges of side panels. Use holes in glides that align with 1st and 3rd pilot holes in the side panels as glides may have more or less holes than illustrated.

STEP 6

Final Cabinet Assembly

A. Invert top onto a smooth flat surface. On Model 64024 there is no difference between the front and back of the Top, On Model 64026 make sure the projected wings are toward the front. Attach the butterfly brackets on each leg to the bottom of the top with 5/8" #8 Screws. See Illustration 6.

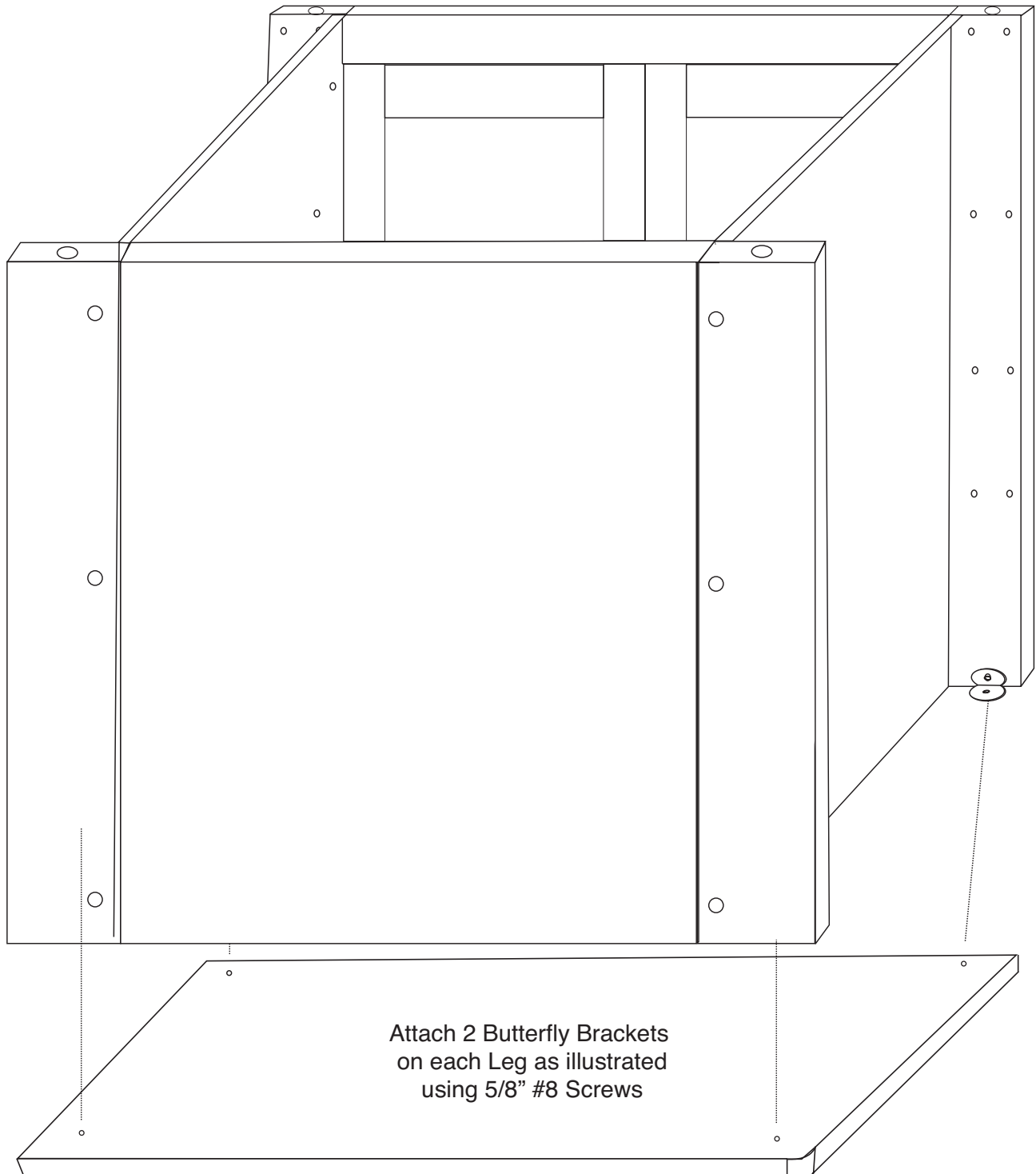

Illustration 6

B. With unit still upside down, tap the 4 caster sockets into the holes in the bottoms of the legs. Tap in the 4 casters by hitting straight down on the solid part of the caster between the wheels.

NOTE: put the 2 locking casters in the front, and the non-locking casters in the back.

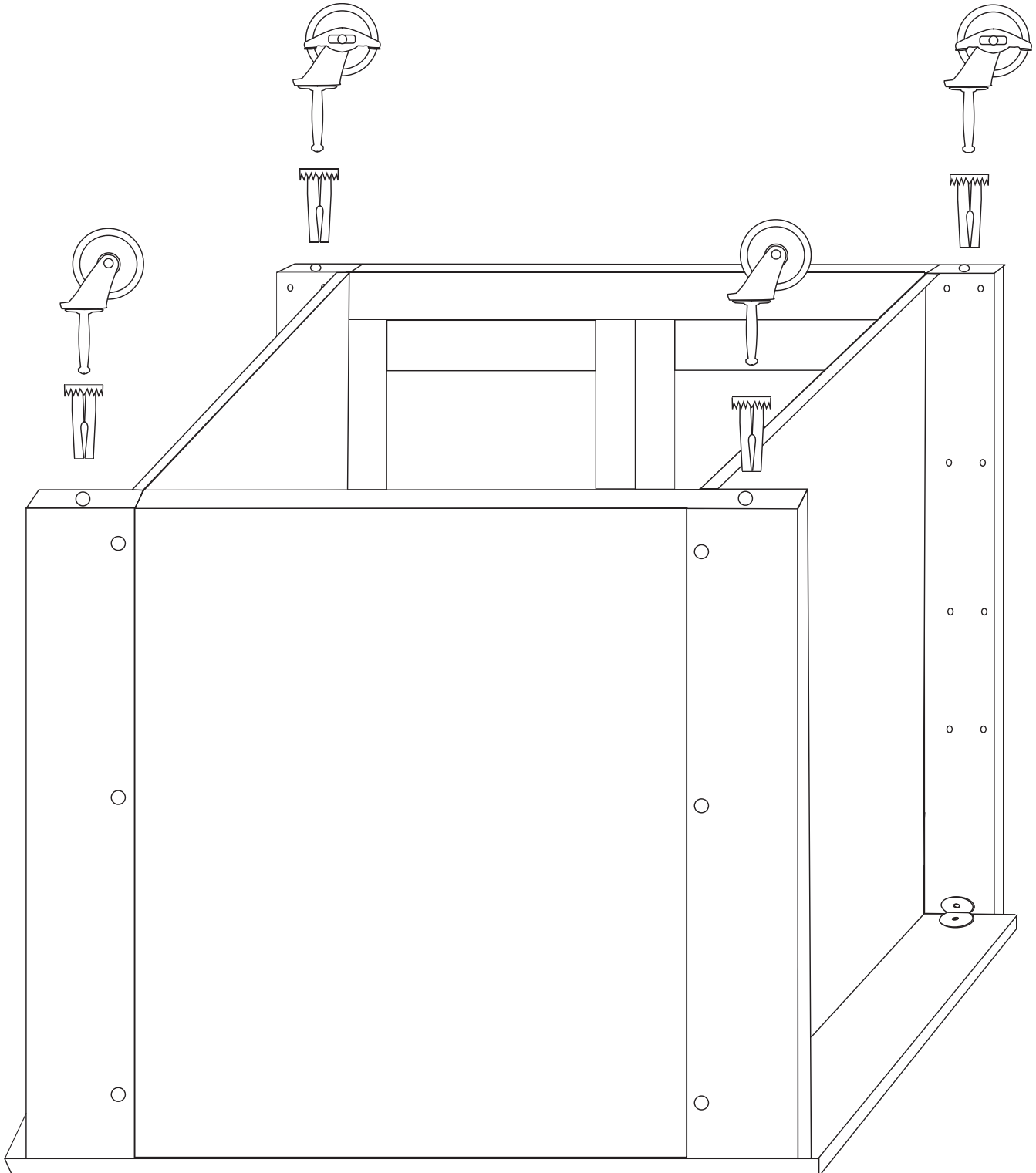

Illustration 6A

C. Upright the unit and tap eight 1" 3/16 diameter steel pins into each leg. Place the side shelves on the pins. Groove in the bottom of the shelves fit over the pins.

D. Open the cabinet doors and tap two 1" pins into the bottom holes of each side panel. Decide where you want the middle shelf (it has 2 adjustments to choose from) and tap two pins into each side panel making sure the pins are aligned side to side. Place the bottom shelf (this shelf has no edge banding) on the back set of pins and lower the front of the shelf until it rests on the back edges of the doors. Close doors and the shelf will drop into place. Take the middle shelf, edge banding out, and place the shelf on the pins. See Illustration 6B for pin locations.

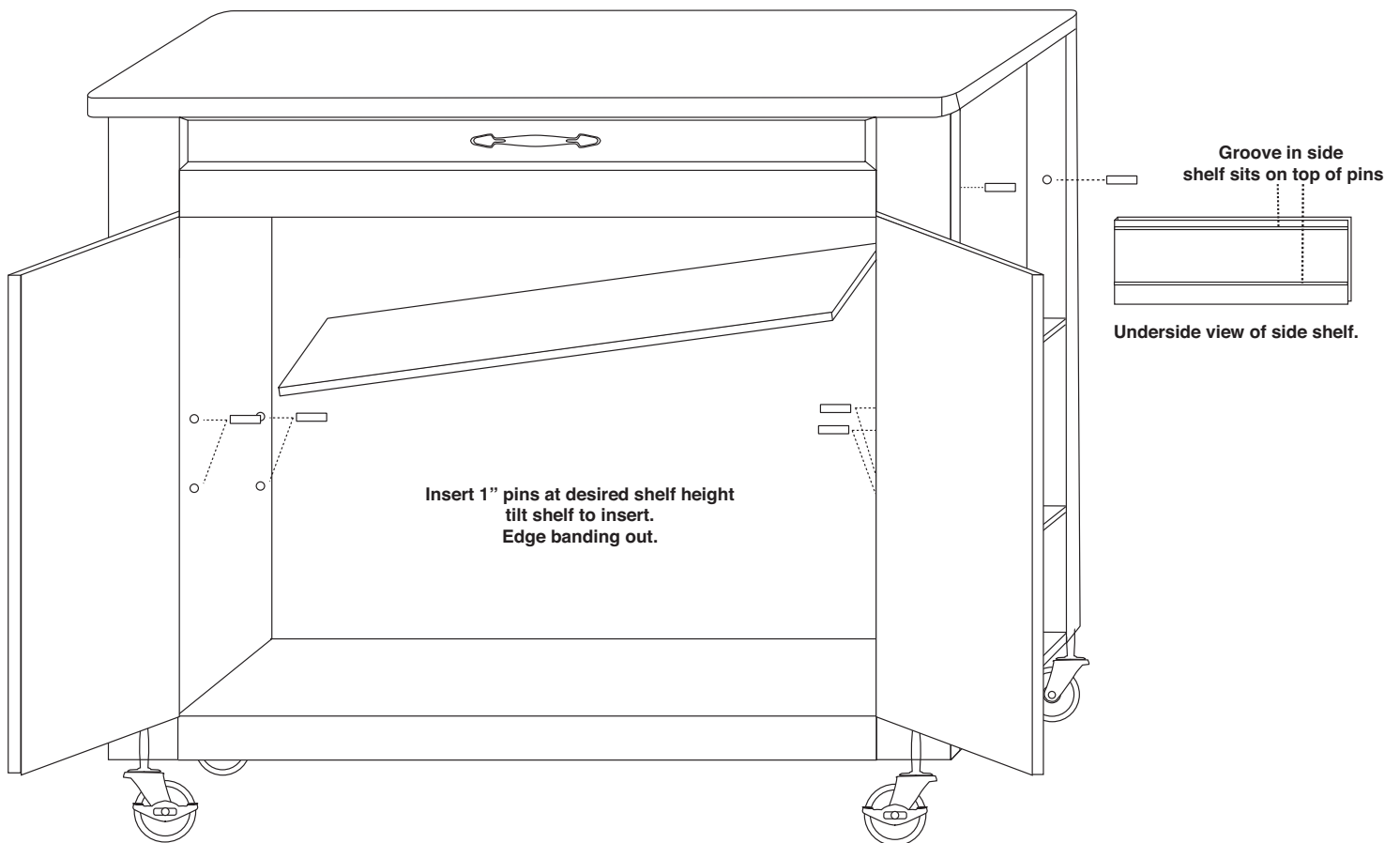

Illustration 6B

TIPS ON HOW THE BASTION FASTENING SYSTEM WORKS

1. The Bastion fastening system consists of a steel post (threaded on one end with a hole through the shaft on the other end); a Barrel Nut (cylindrical barrel-shaped with threaded open end & holes through the sides); and a Set Screw (Phillips slot on one end, pointed on the other)

2. To attach Posts: A) Dip threads of Post in vegetable oil. B) Align threaded end of Post with hole in wood, tap on slotted end with hard hammer until threads enter, then tighten down using a flat head screw driver or the provided allen wrench (See the Illus. Bas. 3 for alternate seating methods). **DO NOT TRY TO HAMMER THE POST ALL THE WAY IN AS IT WILL STRIP THE POST HOLE.** C) When solid shaft of Post hits wood, back out approximately ½ turn until the hole in the posts is properly aligned as per step by step directions. For example: the holes in the posts on the inside of the drawer front will be parallel with the long length of the drawer front when properly seated.

3. A) Place a Barrel Nut into the nut access hole, so that the threads in the nut face out. The small notches on either side of the nut opening, indicate the location of the holes through the sides of the nut. B) Insert the posts through the end of the braces (or drawer sides); through the holes in the sides of the nut. When properly aligned, you will see the hole in the post inside the barrel nut. Post hole should be slightly off-center toward the wood.

4. Insert the Set Screw into the threaded end of the nut and tighten down. The tip of the Set Screw will seek the center of the hole in the Post as it is tightened down, forcing the Nut toward the main shaft of the Post. This is what tightens the wooden parts together. Set screws should thread easily – **DON'T CROSS THREAD!** If Set Screw doesn't thread easily, check position of the hole in Post.

5. If the wooden parts are not tight against each other, the Post needs to be screwed a half turn at a time until wood joints are tight.

Illustration Bas. 1

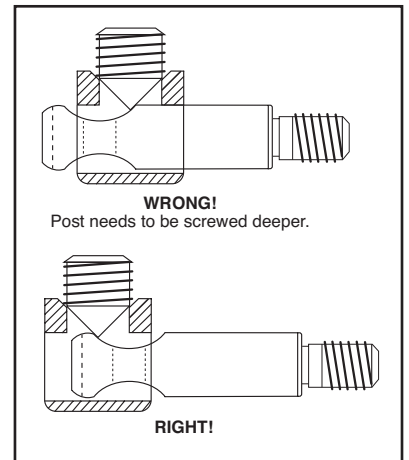
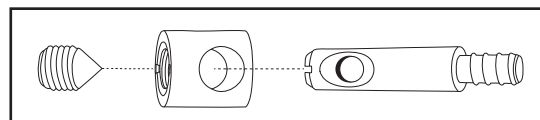
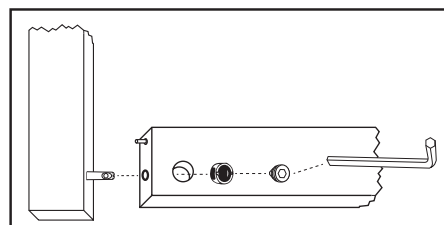

Illustration Bas. 2



Step 2



Allen Wrench Provided

Illustration Bas. 3

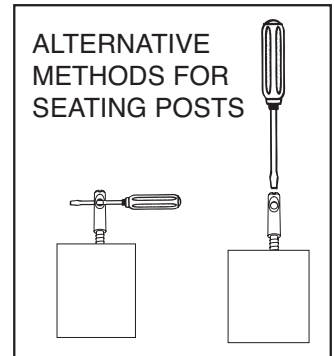

Step 1

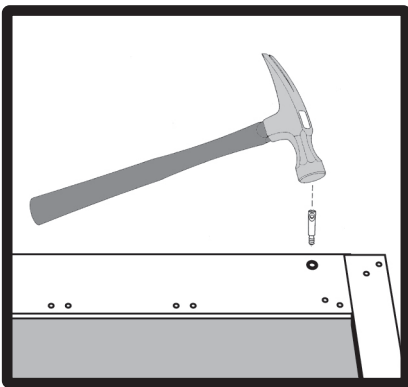

See video on our website!

If you have any questions regarding assembly or missing or damaged parts, call our customer support number:

607-652-7321 or 888-732-7321.

Customer Support Hours are 8am-5pm Mon. - Fri. Eastern Time zone.



For continued beauty and long life of your Catskill Craftsmen cart, we recommend Catskill Craftsmen's Butcher Block Oil.

Our Butcher Block Oil is available directly from Catskill Craftsmen's factory. For one eight ounce (8 fl. oz.) bottle, which is sufficient for two applications, simply send \$6.95 along with the completed coupon to the address below. Visit us online at www.catskillcraftsmen.com to browse our assortment of butcher block care products. Visa and Mastercard are accepted online.



Catskill Craftsmen, Inc.
15 West End Ave.
Stamford, NY 12167-1296



BUTCHER BLOCK OIL COUPON

Please send me _____ # of bottle(s) of the Catskill Craftsmen Butcher Block Oil at \$6.95 per bottle. My check or money order is enclosed for a total of \$_____.

Item code: 64026

Name _____

Address _____

City _____

State _____ Zip _____

Please make checks payable to Catskill Craftsmen Inc. 15 West End Ave., Stamford, NY 12167-1296